

A STRONGHOLD BY PRECISION AND POWER.



DI CHUN IRON WORK CO., LTD.

NO. 7, Jingke 1st Rd., Nantun Dist.,
Taichung City 408, Taiwan(R.O.C.)
Tel: +886-4-2358-5879 Fax: +886-4-2358-3695
www.auto-strong.com





AUTO
Strong

Di Chun Spirit — Our Heart is to be Tolerant of Diversity.

CONTENTS



A STRONGHOLD BY PRECISION AND POWER.

P15 Scroll / Chuck Jaw Chuck



KD
3-jaw strong scroll chuck
D1 camlock direct mounting,
2-piece jaws.



N-200A
3-jaw through-hole power chuck.
(adapter included)



V
3-jaw wedge type non
through-hole power chuck.
(adapter excluded)



VRA
Non through-hole power chuck for
vertical lathe (adapter included).



M
High speed through-hole
rotary hydraulic cylinder.



MS
Non through-hole rotary hydraulic
cylinder.(valve included)



SC
3-jaw scroll chuck plain
back, solid jaws.



KA
3-jaw strong scroll chuck
A1 direct mounting, 2-piece
jaws.



NT-200
2-jaw through-hole power chuck.
(adapter excluded)



VT&VIT
2-jaw and 4-jaw wedge type non
through-hole power chuck.
(adapter excluded)

P37 Collet Chuck



MK
Super high speed through-hole
compact rotary hydraulic cylinder.

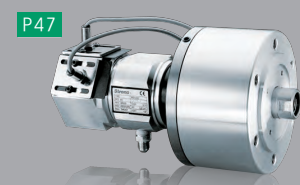

MS-C
Non through-hole rotary hydraulic
cylinder. (valve and switch brackets
included)



SIC
4-jaw scroll chuck plain
back, solid jaws.



SE
6-jaw scroll chuck plain back.



NIT-200
4-jaw through-hole power chuck.
(adapter excluded)



VA
3-jaw wedge type non
through-hole power chuck.
(adapter included)



CR
Collet chuck for cylindrical center
mount.



CM.B
Hydraulic cylinder coolant collector.

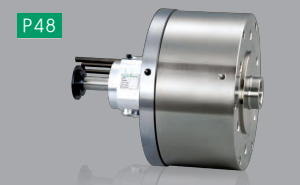

MS250C/MS300C
Non through-hole rotary hydraulic
cylinder. (valve and switch brackets
included)



SK
3-jaw strong scroll chuck
plain back, 2-piece jaws.

P22 Power Chuck



NHT-200
2 jaw and 3 jaw through-hole
power chuck. (adapter included)



V(40"-79")
Large wedge type non
through-hole power chuck.
(adapter excluded)



CRA
Collet chuck for short taper mount.



ML-CM.B
Extra large through-hole rotary
hydraulic cylinder.

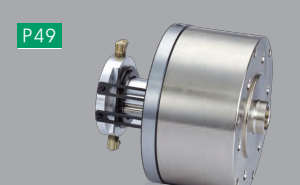

MR
Short Type Non Through Hole
Rotary Hydraulic



SIK
4-jaw strong scroll chuck
plain back, 2-piece jaws.



N-200
3-jaw through-hole power chuck.
(adapter excluded)



NB-200A
3-jaw extra large through-hole
power chuck. (adapter included)



DV/DN
Vertical and vertical horizontal
stationary power chuck.

P39 Hydraulic Cylinder

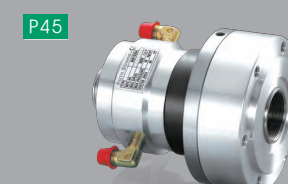

MM
High speed and compact
through-hole rotary hydraulic cylinder



MH
Non through-hole rotary hydraulic
cylinder.

P51

Soft & Hard Jaws

P56



ADAPTER

Mounting adapter on short taper spindle noses DIN55026.

P60

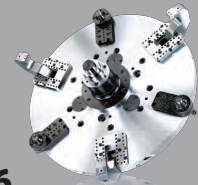

F66

High speed and light weight type strong finger chuck for aluminum wheel.

P65



PB-ES

Pneumatic power chuck.

P51

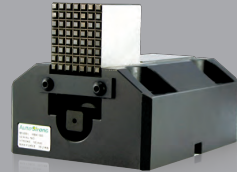

HB4

Boring mill jaw.

P57

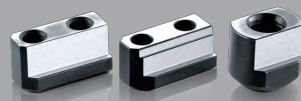

T-UNTS

Suitable for power chuck.

P61



BL

3-jaw ball swing lock chuck.

P66



HC40-1

Soft jaw for hydraulic power chuck

P52



SKC

Soft jaw for strong scroll chuck.

**P58
Special Purpose Power Chucks**

P62

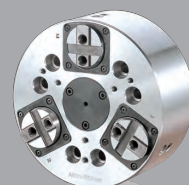

DR

3-jaw draw down power chuck.

P66



HJ40-1

Hard jaw for hydraulic power chuck

P53



HC

Soft jaw for hydraulic power chuck.

P58

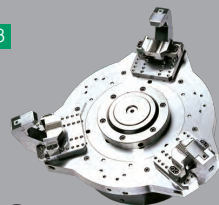

F52

High speed and light weight type strong finger chuck for aluminum wheel.

P63



P165

Floating plate center chuck.

P55

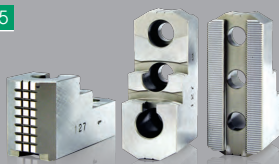

HJ

Hard jaw for hydraulic power chuck.

P59



F61

High speed and light weight type strong finger chuck for aluminum wheel.

P64

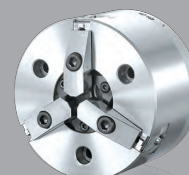

HN

3-jaw extra high speed through-hole power chuck. (adapter included)



**Customer First, Employee's Need,
It is Di Chun's Core Value of Management.**

A sincere enterprise that is worthy to trust-Di Chun. Traditional spirit, innovative technology; people-oriented and treat them as family; solid our career in Taiwan and exploring the world.

Past 40 years, Di Chun insists the spirit of "Quality to be the must and customer must to be the first; do the right thing; seeking the truth and finding the cause" applied to manufacturing various kind of accurate products. We rapidly rose from small or medium-sized companies and factories, but today we are wide continuously recognized and have been honored by supplying worth-trust machine tool equipment to many users.

Di Chun expanded in 1992 and established the brand "Auto Strong" which has a meaning of being precise and strong as eagle's claw, in order to emphasize the quality and high performance of Di Chun products, this is our value to focus on research, development and innovation, solid our career in Taiwan then head to the international machine tool equipment market; meanwhile, the precise production process were compliments by our customers.

Until now, Di Chun not only insist strict quality control, but emphasize the six policies of "personal cultivating, innovation constantly, flexible thinking, uplift the career, global vision, outstanding products" symbolizes the contemplation of Di Chun "Head to the global market and Taiwan will be known everywhere."

The competition advantage is the capital for most business, but what support Di Chun to sustainable development is a team united as a strong family. We insist a concept of "tolerance diversity, placing every employee to the right position", in order to advance the ability, we create a comfortable working environment, training them to be specialist and share the profit together. There is an ancient Chinese saying: "If people's hearts together, the great mountain can be moved", Di Chun policy is based on traditional Taiwanese spirits which is serious and responsible, and completely reflected the best quality of "Made in Taiwan".

Di Chun represents the culture of "people-oriented" and participate this policy in various aspects: "Traditional spirits, based on honor, reliable quality; new concepts, understanding the trend of the world; advanced technology, research innovative, challenge beyond the limit."

Today, Di Chun persists developing product perfect than ever not only by approved by ISO & CE, but severe self-demanding, This is what we perform and doubtless we have confidence that we are going to be the top one machine tool equipment manufacturer in the future.

This is Di Chun, create miracles, worth trusting.

Innovation is recorded by time

Di Chun is proud of its achievement today, but not complacent, because every step along the way was hard, these were earned carefully.

Besides treasuring what we have now, also remind ourselves through the past experience. Challenge our limit at every moment. Let innovation be recorded by time.



- 1970**
- 1974 Established Yong Yu Machinery Factory on Zhenxing Rd. in Taichung, and manufactured 3-jaw scroll chucks professionally.
 - 1976 Quality was affirmed by the machine tool maker, and 3-jaw scroll chucks started being mass produced.
 - 1977 The group changed and established Di Chun Iron Work Co., LTD., and expanded business by relocating the factory to Yonghe St. in Taichung City. The R&D Department was established, and a range of interchangeable chuck jaws for hydraulic chucks were successfully developed.
 - 1978 Purchased CNC lathes and Machining Centers, production becomes fully automated.
- 1980**
- 1980 Cooperated with ONO Machine & Tool Co. Ltd., as a joint venture, and successfully entered into the Japanese market.
 - 1982 Researched and developed special purpose precision drilling machine and entered into the business operations.
 - 1984 The operation of the whole factory was upgraded to computerized data management.
 - 1987 Along with the government, the strategic components strategic standards were promoted and also entered into the research of jaws for CNC lathe chucks.
 - 1988 Successfully researched and developed hydraulic 3-jaw scroll chucks and super high-speed rotary hydraulic cylinders for CNC lathes in cooperation with the Mechanical and Systems Research Laboratories of Industrial Technology Research Institute.
- 1990**
- 1991 Awarded the approval of MCS (Mechanical Component Standard) certification.
 - 1992 Expanded the company's operations, and increased the capital to NT\$ 50 million, and relocated to Wu Jih Factory. Entered into the international automation equipment market.
 - 1993 Established Beijing and Shenyang offices in mainland China. Promoted total quality control. Adopted 100% Meehanite for the main body of the 3-jaw scroll chucks.
 - 1995 Passed the CE (Conformité Européenne) marking certification. The company officially changed the Chinese name to Di Chun Iron Work Co., LTD. (the English name remained the same). Products honored with Golden Tripod Award by the Air/Oil Hydraulic Society.
 - 1996 Passed the ISO-9002 Quality Assurance System certification.
 - 1997 Researched and developed the following items: M2511 high-speed rotary hydraulic cylinders (15"), MS Non through-hole rotary hydraulic cylinders with built-in safety device, MSC Non through-hole rotary hydraulic cylinders with built-in safety & detection device, and CT42 precision collet chucks.
 - 1998 Researched and developed: V218 Non through-hole hydraulic chucks.
 - 1999 Researched and developed: V244 Non through-hole hydraulic chucks.
- 2000**
- 2000 Researched and developed: finger chucks for aluminum wheels.
 - 2001 Researched and developed: MM0933 and MM1033 through-hole rotary hydraulic cylinders.
 - 2002 Researched and developed in June: HN06 ten thousand rpm hydraulic chucks and HG296 ten thousand rpm hydraulic cylinders. Passed the ISO-9001 Quality Assurance System certification in September.
 - 2003 Researched and developed: HB4 boring mill, P165 floating plate center chuck, and N204- and NB-series extra-large through-hole chucks.
 - 2004 Expanded the factory complex. Researched and developed: DR-series draw down chucks and BL-series ball swing lock chucks.
 - 2005 Researched and developed: F52 12"~18" finger chucks for aluminum wheels.
 - 2006 Researched and developed: F61 13"~22" and F66 17"~24" finger chucks for aluminum wheels.
 - 2007 Researched and developed: V240(1000mm) Non through-hole hydraulic chucks and MS250C Non through-hole rotary hydraulic cylinders.
 - 2008 Researched and developed: V250(1250mm) Non through-hole hydraulic chuck and VE263(1600mm) extra-large vertical lathe Non through-hole chucks.
 - 2009 Researched and developed: ML-2816 extra-large through-hole rotary hydraulic cylinders.
- 2010**
- 2010 Researched and developed: ML-3320 extra-large through-hole rotary hydraulic cylinders.
 - 2011 Researched and developed: VE 279(2000mm) Non through-hole hydraulic chucks and MS300C Non through-hole rotary hydraulic cylinders.
 - 2012 Researched and developed: PB-ES600-275 pneumatic power chucks and MR250 Non through-hole compact rotary hydraulic cylinders.
 - 2013 Researched and developed: PB-ES850-375 pneumatic power chucks and the factory was relocated to Precision Machinery Park to expand its operations.



A STRONGHOLD BY PRECISION AND POWER.

Precise Manufacturing Process

Chuck is the main component of the lathe; it's not only lightweight and resilient, but also stable and solid. Di Chun always insist traditional principle: "Quality Stabilized", "Energy Efficiency", "Standard specification", and fully understand the trend of the world, in order to transcend the limit of our manufacture process, which based on innovative ideas and advanced technology.

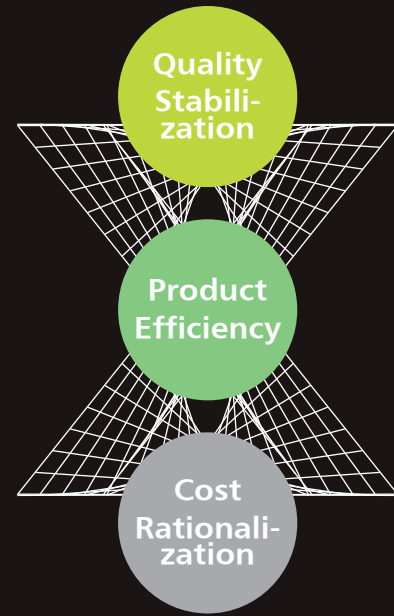

Product Advantages

- It is smaller and lighter than the regular products, and it is more stable during high speed rotation, reduce the spindle loading.
- Manufactured by aluminum alloy, it is lightweight, the machine can elaborate its features, and equipped with a safety lock mechanism.
- Parts standardization, high-speed, high clamping force, easy to assemble operation, and durable.
- Low noise, pollution-free.



Strict Quality Control

Even the precise manufacturing process still need the strict quality control, Di Chun does not only get several domestic rewards, but also approved by CE & ISO-9001 certifications. Di Chun insists its quality control through the tool of IMPACT Three Dimensional Testing and TESA Height Gauge to offer the best product to customers.



A STRONGHOLD BY PRECISION AND POWER.

“Auto Strong” Well-known Reputation over 20 Years

20 years ago, when most Taiwanese enterprises which making a decision between OEM, ODM or OBM, Di Chun already insight for developing its own brand, “AUTO STRONG” was established by creativity and innovation. Di Chun has possessed 70% domestic market and become the pioneer beyond its competitors during a decade. These achievements are created by all Di Chun members together.

Di Chun’s foundation is based on our professional team work. In 1995, Di Chun was ahead of competitors to entering the European market by CE certification and domestic award.

Di Chun, a world- class factory, a symbol of good quality and a professional developing create the reliable product worldwide such as Great Britain, United States, Germany, Italy, China, Thailand, Indonesia, Malaysia, Japan, Brazil, Soviet Union, Singapore and get good reputation from them.

Marketing construction and sales network built by professional team and become the pioneer among the realm of machine tool equipment manufacturing. Besides, Auto Strong products focus not only on high quality, but excellence.

Even global changed itself rapidly, Di Chun insist one policy, developing new product, display our highly efficiency and professional, and create our value to the top level. Auto Strong, as precise as eagle’s claw, is what Di Chun shows and captures customer’s hearts.

Di Chun, create miracles, worth trusting.



SC

3-jaw scroll chuck plain back, solid jaws (front and back mounted)

1. Interchangeable utilization of internal and external hard jaws.
2. SC types feature economical and durable, suitable for mass production.
3. Gripping accuracy of 0.03mm (0.0012 inch) T.I.R..
4. The body is made of MEEHANITE. It is suitably used for high speed revolution and 3 times more durable than regular material.

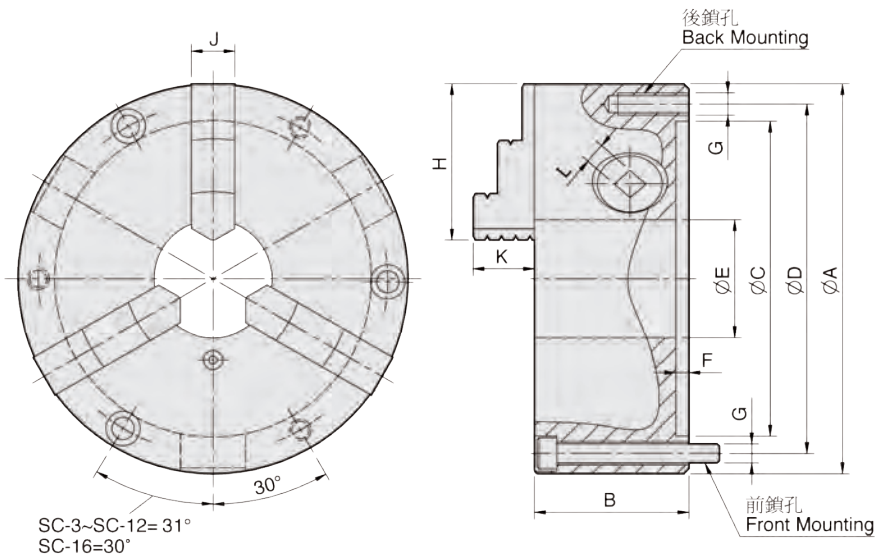

SIC

4-jaw scroll chuck plain back, solid jaws (front and back mounted)

1. Gripping of square or octagonal workpieces could fit into central line automatically.
2. SIC have high stability in gripping thin tube work piece.
3. The specification is the same as SC type.
4. The body is made of MEEHANITE. It is suitably used for high speed revolution and 3 times more durable than regular material.

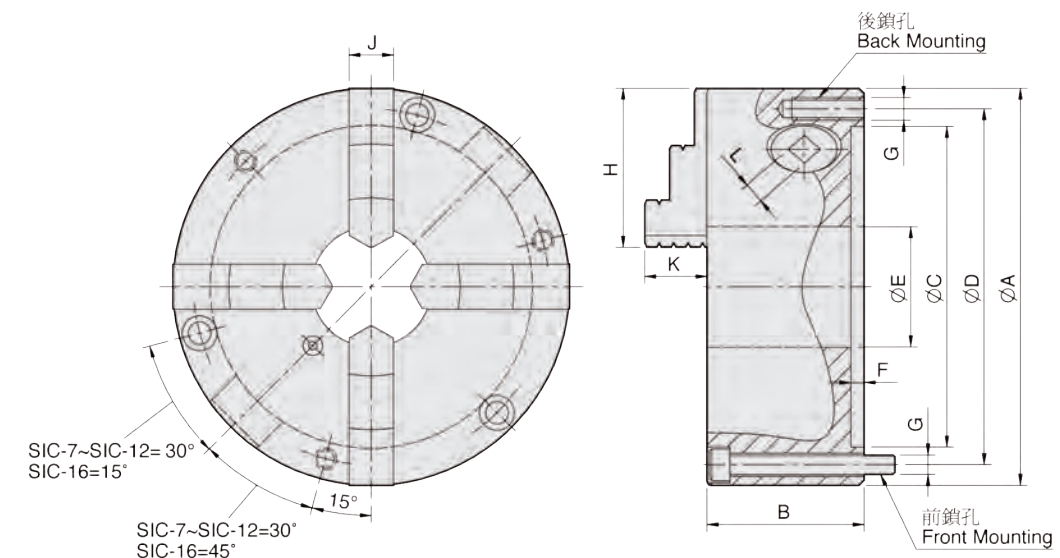

UNIT mm

SPEC Model	A	B	C	D	E	F	G Back / Front	H	J	K	L	Allowable Handle Torque (kgf·m)	Gripping Force (kgf)	Max. Speed (r.p.m.)	Weight (kg)	Moment Of Inertia I (kg·m ²)	Gripping Range O.D. Range / I.D. Range
SC-3	86	46	60	73	16	4.1	3-M6 / 3-M6x50	36	11	14.3	7	3.0	900	2500	1.7	—	Ø2-Ø70 / Ø24-Ø64
SC-4	112	60	80	95	24	4.8	3-M8 / 3-M8x70	42	14	16.6	8	4.5	1200	2500	3.7	—	Ø3-Ø95 / Ø29-Ø84
SC-5	132	60	100	115	32	4.8	3-M8 / 3-M8x70	50	16	20.3	8	6.5	1500	2500	5.2	0.01	Ø3-Ø110 / Ø33-Ø100
SC-6	167	67	130	147	45	5.5	3-M10 / 3-M10x70	63	19	23.7	10	9.0	2200	2000	9.3	0.03	Ø4-Ø160 / Ø48-Ø150
SC-7	192	76.5	155	172	58	5.5	3-M10 / 3-M10x80	77	21.5	29.4	11	11.0	2500	2000	14.2	0.06	Ø4-Ø180 / Ø56-Ø170
SC-8	200	76.5	160	176	58	5.5	3-M10 / 3-M10x80	77	21.5	29.4	11	11.0	2500	2000	16	0.07	Ø4-Ø190 / Ø62-Ø180
SC-9	232	84	190	210	70	6	3-M12 / 3-M12x90	87	24	35.6	12	15.0	3000	2000	22.7	0.15	Ø5-Ø220 / Ø62-Ø210
SC-10	273	87	230	250	89	8	3-M12 / 3-M12x90	98	28	39.5	12	19.5	4000	1800	31.8	0.25	Ø6-Ø260 / Ø70-Ø250
SC-12	310	96	260	285	105	7	3-M12 / 3-M12x110	110	30	45.6	14	21.0	4200	1800	44.8	0.58	Ø10-Ø300 / Ø86-Ø290
SC-16	405	122	345	375	160	8.7	— / 6-M14x130	146	42	56.3	15	25.0	4500	1500	102	1.75	Ø30-Ø380 / Ø110-Ø360

UNIT mm

SPEC Model	A	B	C	D	E	F	G Back / Front	H	J	K	L	Allowable Handle Torque (kgf·m)	Gripping Force (kgf)	Max. Speed (r.p.m.)	Weight (kg)	Moment Of Inertia I (kg·m ²)	Gripping Range O.D. Range / I.D. Range
SIC-7	192	76.5	155	172	58	5.5	3-M10 / 3-M10x80	77	21.5	29.4	11	11.0	2500	2000	14.8	0.06	Ø4-Ø180 / Ø56-Ø170
SIC-9	232	84	190	210	70	6	3-M12 / 3-M12x90	87	24	35.6	12	15.0	3000	2000	23.2	0.16	Ø5-Ø220 / Ø62-Ø210
SIC-12	310	96	260	285	105	7	3-M12 / 3-M12x110	110	30	45.6	14	21.0	4200	1800	47	0.58	Ø10-Ø300 / Ø86-Ø290
SIC-16	405	122	345	375	160	8.7	— / 6-M14x130	146	42	56.3	15	25.0	4500	1500	107	1.72	Ø30-Ø380 / Ø110-Ø360

SK

3-jaw strong scroll chuck plain back, 2-piece jaws (front and back mounted)



1. SK types chucks have wider utilization range; hard jaws suitable for heavy cutting; soft jaws suitable for light and precision cutting.
2. Hard jaws could be used as internal jaws and external jaws.
3. Gripping accuracy of 0.03mm (0.0012 inch) T.I.R.
4. The body is made of MEEHANITE. It is suitably used for high speed revolution and 3 times more durable than regular material.

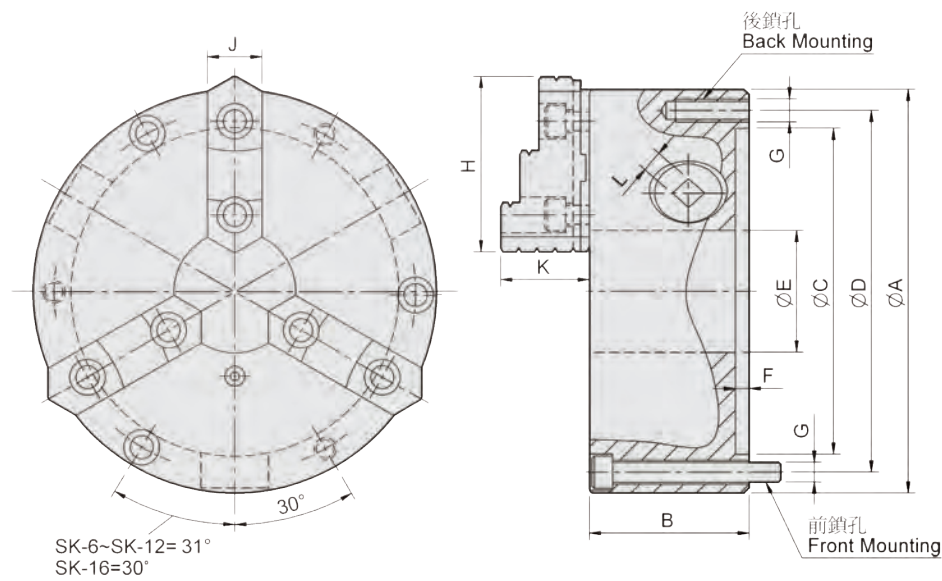

SIK

4-jaw strong scroll chuck plain back, 2-piece jaws (front and back mounted)



1. Hard jaws are adopted for square or octagonal thin tube workpieces machining.
2. Soft jaws could grip rectangular workpiece after being unisotropic machined.
3. The specification is the same as SK type.
4. The body is made of MEEHANITE. It is suitably used for high speed revolution and 3 times more durable than regular material.

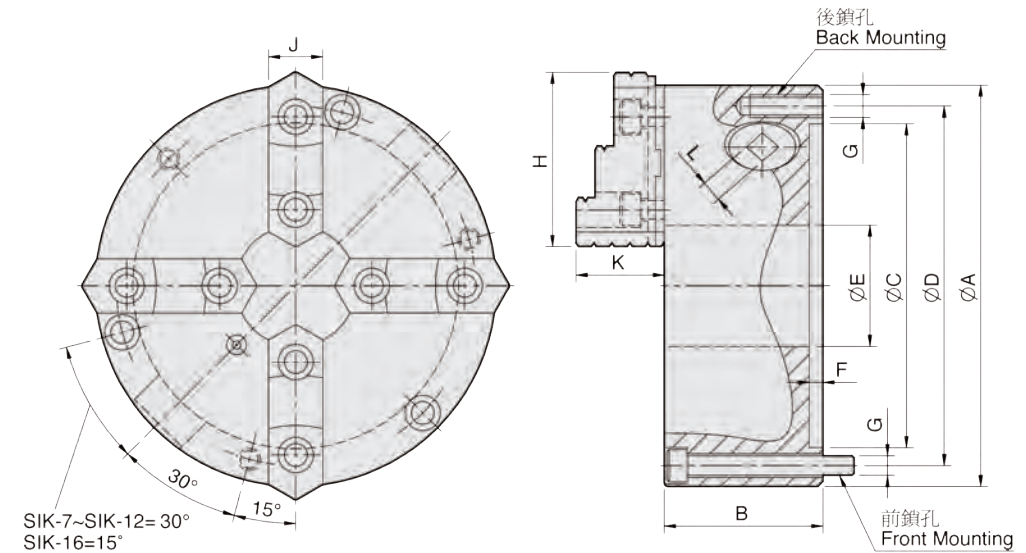

UNIT : mm

SPEC Model	A	B	C	D	E	F	G Back / Front	H	J	K	L	Allowable Handle Torque (kgf · m)	Gripping Force (kgf)	Max. Speed (r.p.m.)	Weight (kg)	Moment Of Inertia I (kg · m ²)	Gripping Range O.D. Range / I.D. Range
SK-4	112	58	80	95	32	4.8	3-M8 / 3-M8x65	47	19	31.6	8	4.5	1200	2500	3.8	—	Ø3-Ø95 / Ø29-Ø84
SK-6	167	67	130	147	45	5.5	3-M10 / 3-M10x70	72	26	40.2	10	9.0	2200	2000	9	0.03	Ø4-Ø160 / Ø55-Ø150
SK-7	192	76.5	155	172	58	5.5	3-M10 / 3-M10x80	81.2	28	42	11	11.0	2500	2000	13.8	0.06	Ø8-Ø180 / Ø62-Ø170
SK-8	200	76.5	160	176	58	5.5	3-M10 / 3-M10x80	82	28	42	11	11.0	2500	2000	15.5	0.07	Ø8-Ø190 / Ø68-Ø180
SK-9	232	84	190	210	70	6	3-M12 / 3-M12x90	90.9	32	51.2	12	15.0	3000	2000	22	0.16	Ø11-Ø220 / Ø70-Ø210
SK-10	273	87	230	250	89	8	3-M12 / 3-M12x90	100.5	35	56.7	12	19.5	4000	1800	29.7	0.26	Ø12-Ø260 / Ø80-Ø250
SK-12	310	96	260	285	105	7	3-M12 / 3-M12x110	114.5	40	56.8	14	21.0	4200	1800	43.5	0.58	Ø15-Ø300 / Ø90-Ø290
SK-16	405	122	345	375	160	8.7	— / 6-M14x130	148.6	50	76.1	15	25.0	4500	1500	98	1.72	Ø30-Ø380 / Ø110-Ø360

UNIT : mm

SPEC Model	A	B	C	D	E	F	G Back / Front	H	J	K	L	Allowable Handle Torque (kgf · m)	Gripping Force (kgf)	Max. Speed (r.p.m.)	Weight (kg)	Moment Of Inertia I (kg · m ²)	Gripping Range O.D. Range / I.D. Range
SIK-7	192	76.5	155	172	58	5.5	3-M10 / 3-M10x80	82	28	42	11	11.0	2500	2000	14.1	0.06	Ø8-Ø180 / Ø62-Ø170
SIK-9	232	84	190	210	70	6	3-M12 / 3-M12x90	96	32	51.2	12	15.0	3000	2000	22.2	0.16	Ø11-Ø220 / Ø70-Ø210
SIK-12	310	96	260	285	105	7	3-M12 / 3-M12x110	114.5	40	56.8	14	21.0	4200	1800	45	0.58	Ø15-Ø300 / Ø90-Ø290
SIK-16	405	122	345	375	160	8.7	— / 6-M14x130	148.6	50	76.1	15	25.0	4500	1500	108	1.72	Ø30-Ø380 / Ø110-Ø360

KD

3-jaw strong scroll chuck D1 camlock direct mounting, 2-piece jaws

(ASA spindle nose D1-4, D1-5, D1-6, D1-8)
American standard camlock type with 2-piece reversible hard top jaws.

1. Gripping accuracy of 0.03mm (0.0012 inch) T.I.R..
2. Standard accessories chuck wrench, hex. key. and a set of mounting bolts. (UNC-bolts)
3. The body is made of MEEHANITE. It is suitably used for high speed revolution and 3 times more durable than regular material.

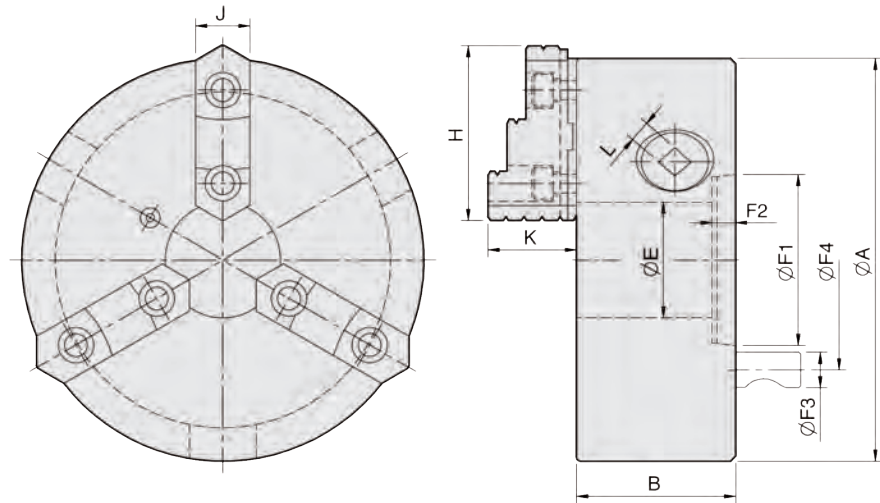

KA

3-jaw strong scroll chuck A1 direct mounting, 2-piece jaws

(ASA spindle nose A1-5, A1-6)
American standard camlock type with 2-piece reversible hard top jaws.

1. Gripping accuracy of 0.03mm (0.0012 inch) T.I.R..
2. Standard accessories chuck wrench, hex. key. and a set of mounting bolts. (UNC-bolts)
3. The body is made of MEEHANITE. It is suitably used for high speed revolution and 3 times more durable than regular material.

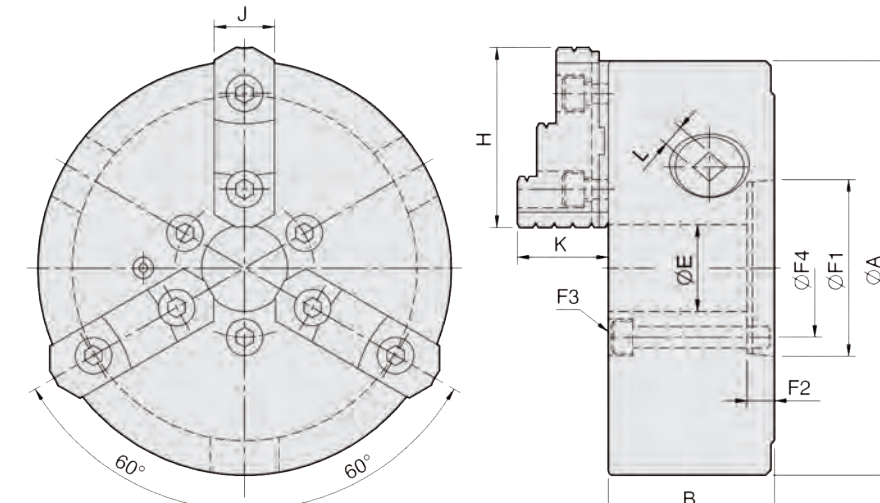

UNIT : mm

SPEC Model	Spindle Size	A	B	E	H	J	K	L	Mounting Dimensions				Allowable Handle Torque (kgf·m)	Gripping Force (kgf)	Max. Speed (r.p.m.)	Weight (kg)	Moment Of Inertia I (kg·m²)	Gripping Range O.D. Range / I.D. Range
									F1	F2	F3	F4						
KD4-6"	D1-4	165	71	40	72	26	39.5	10	63.513	13	15.8	82.55	9.0	2200	2000	11	0.04	Ø8-Ø160 / Ø55-Ø150
KD4-8"	D1-4	200	77.2	53	82	28	42.2	11	63.513	13	15.8	82.55	11.5	2500	2000	18.5	0.07	Ø8-Ø180 / Ø62-Ø170
KD5-8"	D1-5	200	77.2	55	82	28	42.2	11	82.563	16	19	104.78	11.5	2500	2000	18	0.07	Ø8-Ø180 / Ø62-Ø170
KD6-8"	D1-6	200	77.2	58	82	28	42.2	11	106.375	17	22.2	133.35	11.5	2500	2000	17	0.07	Ø8-Ø180 / Ø62-Ø170
KD6-10"	D1-6	250	86	76	90.9	32	50.8	12	106.375	17	22.2	133.35	19.5	4000	1800	29.5	0.2	Ø11-Ø220 / Ø70-Ø210
KD6-12"	D1-6	306	107.5	103	114.5	40	57.8	14	106.375	13.5	22.2	133.35	21.0	4200	1800	47	0.5	Ø15-Ø300 / Ø90-Ø290
KD8-10"	D1-8	250	86	80	90.9	32	50.8	12	139.719	19	25.4	171.45	19.5	4000	1800	27	0.2	Ø11-Ø220 / Ø70-Ø210
KD8-12"	D1-8	306	107.5	103	114.5	40	57.8	14	139.719	18	25.4	171.45	21.0	4200	1800	47	0.5	Ø15-Ø300 / Ø90-Ø290

UNIT : mm

SPEC Model	Spindle Size	A	B	E	H	J	K	L	Mounting Dimensions				Allowable Handle Torque (kgf·m)	Gripping Force (kgf)	Max. Speed (r.p.m.)	Weight (kg)	Moment Of Inertia I (kg·m²)	Gripping Range O.D. Range / I.D. Range
									F1	F2	F3	F4						
KA5-8"	A1-5	200	77.2	40	81.2	28	42.2	11	82.563	14.288	3-M10	61.9	11.0	2500	2000	18	0.07	Ø8-Ø180 / Ø62-Ø170
KA6-8"	A1-6	200	77.2	53	81.2	28	42.2	11	106.375	15.875	3-M12	82.6	11.0	2500	2000	18	0.07	Ø8-Ø180 / Ø62-Ø170
KA6-10"	A1-6	250	86	53	90.9	32	50.8	12	106.375	15.875	3-M12	82.6	19.0	4000	1800	29.5	0.2	Ø11-Ø220 / Ø70-Ø210
KA6-12"	A1-6	306	107.5	53	114.5	40	57.8	14	106.375	15.875	3-M12	82.6	21.0	4200	1800	47	0.5	Ø15-Ø300 / Ø90-Ø290
KA8-12"	A1-8	306	107.5	77	114.5	40	57.8	14	139.719	17.462	6-M16	111.1	21.0	4200	1800	47	0.5	Ø15-Ø300 / Ø90-Ø290



SE

6-jaw scroll chuck plain back

1. SE types are specially meet for drilling*endmilling*tapping or grinding in tool grinders.
2. Huge bore diameter design for wider application of bar workpieces.
3. SE type feature gripping for thin tube and high roundness accuracy.
4. The body is made of MEEHANITE. It is suitably used for high speed revolution and 3 times more durable than regular material.

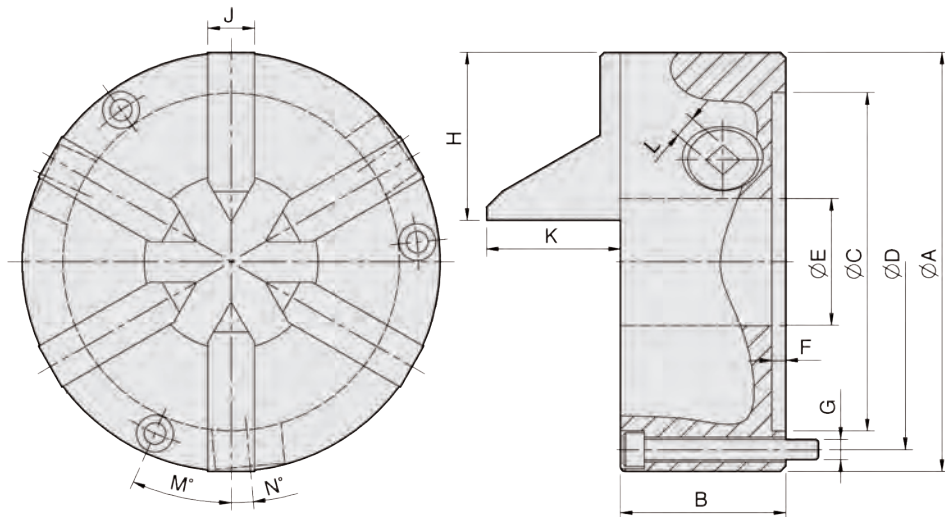

N-200

3-jaw through-hole power chuck (adapter excluded)

- More large bore :
- The largest bore in wedge type power operated chucks.

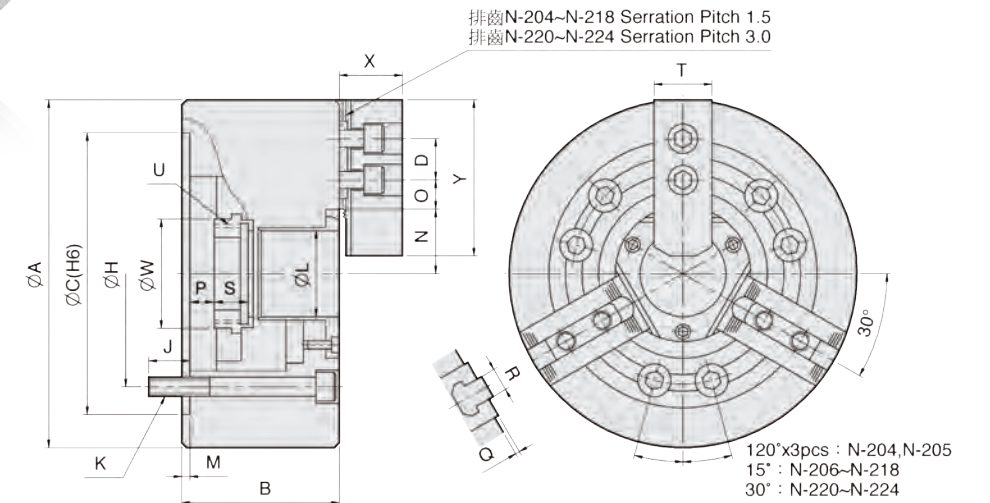

UNIT : mm

SPEC Model	Through-Hole (mm)	Plunger Stroke (mm)	Jaw stroke (In Dia.) (mm)	Max. Pull Force (kgf)	Max. Gripping Force (kgf)	Max. Operating Pressure (kgf / cm ²)	Max. Speed (r.p.m.)	Weight (kg)	Moment Of Inertia I (kg · m ²)	Matching Cylinder	Matching Hard Jaw	Matching Soft Jaw	Gripping O.D. Range (mm)
N-204	Ø26	10	5.4	1428	2906	31.6	8000	4	0.007	M0928	HJ05	HC04	Ø4-Ø110
N-205	Ø33	10	5.4	1784	3671	28.5	7000	7	0.018	M1036	HJ05	HC05	Ø6-Ø135
N-206	Ø45	12	5.5	2243	5812	28.5	6000	13.5	0.057	M1246	HJ06	HC06	Ø15-Ø169
N-208	Ø52	16	7.4	3558	9075	26.5	5000	23	0.17	M1552	HJ08	HC08	Ø20-Ø210
N-210	Ø75	19	8.8	4385	11319	27.5	4200	35	0.315	M1875	HJ10	HC10	Ø25-Ø254
N-212	Ø91	23	10.6	5812	14990	27.5	3300	56.5	0.737	M2091	HJ12	HC12	Ø30-Ø304
N-215	Ø117.5	23	10.6	7240	18355	23.5	2500	111	2.27	M2511	HJ15	HC15	Ø50-Ø381
N-218	Ø117.5	23	10.6	7240	18355	23.5	2000	131	3.55	M2511	HJ15	HC15	Ø50-Ø450
N-220	Ø180	23	10.6	9177	23861	30.6	1800	190	6.5	ML2816	HJ24-1	HC24-1	Ø120-Ø510
N-224	Ø205	26	12	9177	23861	26.5	1400	270	14.8	ML3320	HJ24-1	HC24-1	Ø150-Ø610
N-232	Ø230	34	18	10197	24472	29.5	1200	470	41	ML3320	HJ24-1	HC24-1	Ø210-Ø800

DIM Model	A	B	C (H6)	D	H	J	K	L	M	N max.	O max.	O min.	P max.	P min.	Q	R	S	T	U max.	W	X	Y
N-204	110	59	85	14	70.6	16	3-M10x60	26	4	23.2	13.75	6.75	3.5	-6.5	2	10	17.5	23	M32x1.5	38	24	49.5
N-205	135	60	110	14	82.55	15	3-M10x60	33	4	26.5	19.75	7.75	1	-9	2	10	20	25	M40x1.5	45	31	54
N-206	169	81	140	20	104.78	16	6-M10x80	45	5	32	22.75	9.25	11	-1	2	12	19	31	M55x2	60	37	73
N-208	210	91	170	25	133.35	20	6-M12x90	52	5	38.7	29.75	11.75	14.5	-1.5	2	14	20.5	35	M60x2	66	38	95
N-210	254	100	220	30	171.45	22	6-M16x100	75	5	51	33.75	14.25	8.5	-10.5	2	16	25	40	M85x2	94	43	110
N-212	304	110	220	30	171.45	23	6-M16x110	91	6	61.3	45.75	15.75	8	-15	2	21	28	50	M100x2	108	51	130
N-215	381	133	300	43	235	30	6-M20x135	117.5	6	82	45.25	15.25	7	-16	5	22	43	62	M130x2	139	66	165
N-218	450	133	300	43	235	30	6-M20x135	117.5	6	82	79.75	15.25	7	-16	5	22	43	62	M130x2	139	66	165
N-220	510	134	380	60	330.2	35	6-M24x135	180	6	112.5	60.5	24.5	11	-12	5	25	38	64	M190x3	206	73	180
N-224	610	147	520	60	463.6	35	6-M24x150	205	6	139.9	87.5	24.5	16	-10	5	25	38	64	M215x3	230	73	180
N-232	800	150	520	60	463.6	35	6-M24x150	230	6	162	153.5	24.5	16	-18	5	25	38	64	M250x3	262	73	180

UNIT : mm

SPEC Model	A	B	C	D	E	F	G	H	J	K	L	M	N	Allowable Handle Torque (kgf · m)	Gripping Force (kgf)	Max. Speed (r.p.m.)	Weight (kg)	Moment Of Inertia I (kg · m ²)	Gripping O.D. Range
SE-4	112	66	80	95	32	4.8	3-M8x65	45	14	39.7	8	30	6.5	1.6	440	1200	4	—	Ø2-Ø32
SE-6	165	67	130	147	51	5.5	3-M8x70	66.5	19	40.7	10	23.3	6.2	2.8	660	1200	9	0.03	Ø3-Ø51
SE-7	192	76.5	155	172	80	5.5	3-M10x75	77	21.5	61.5	11	24	5.3	3.6	850	1000	14	0.06	Ø3-Ø81



N-200A

3-jaw through-hole power chuck (adapter included)

1. More large bore : The largest bore in wedge type power operated chucks.
2. Model N-200A chucks are assembled with adaptor for ASA B5.9 type A spindles.

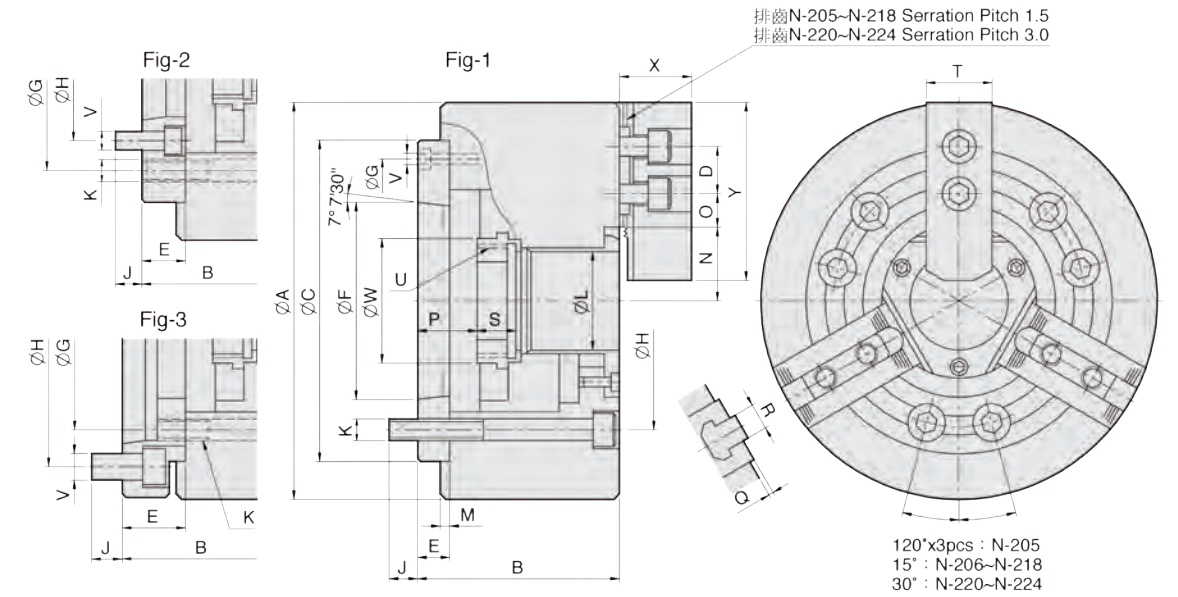

UNIT : mm

SPEC Model	Through-Hole (mm)	Plunger Stroke (mm)	Jaw Stroke (In Dia.) (mm)	Max. Pull Force (kgf)	Max. Gripping Force (kgf)	Max. Operating Pressure (kgf / cm ²)	Max. Speed (r.p.m.)	Weight (kg)	Moment Of Inertia I (kg · m ²)	Matching Cylinder	Matching Hard Jaw	Matching Soft Jaw	Gripping O.D. Range (mm)
N-205A4	Ø33	10	5.4	1784	3671	28.5	7000	7.8	0.020	M1036	HJ05	HC05	Ø6-Ø135
N-205A5	Ø33	10	5.4	1784	3671	28.5	7000	9	0.023	M1036	HJ05	HC05	Ø6-Ø135
N-206A4	Ø45	12	5.5	2243	5812	28.5	6000	15.5	0.065	M1246	HJ06	HC06	Ø15-Ø169
N-206A5	Ø45	12	5.5	2243	5812	28.5	6000	14.7	0.062	M1246	HJ06	HC06	Ø15-Ø169
N-206A6	Ø45	12	5.5	2243	5812	28.5	6000	17.3	0.073	M1246	HJ06	HC06	Ø15-Ø169
N-208A5	Ø52	16	7.4	3558	9075	26.5	5000	25.8	0.190	M1552	HJ08	HC08	Ø20-Ø210
N-208A6	Ø52	16	7.4	3558	9075	26.5	5000	25	0.184	M1552	HJ08	HC08	Ø20-Ø210
N-208A8	Ø52	16	7.4	3558	9075	26.5	5000	29.3	0.217	M1552	HJ08	HC08	Ø20-Ø210
N-210A6	Ø75	19	8.8	4385	11319	27.5	4200	41	0.370	M1875	HJ10	HC10	Ø25-Ø254
N-210A8	Ø75	19	8.8	4385	11319	27.5	4200	38	0.340	M1875	HJ10	HC10	Ø25-Ø254
N-210A11	Ø75	19	8.8	4385	11319	27.5	4200	48.4	0.436	M1875	HJ10	HC10	Ø25-Ø254
N-212A6	Ø91	23	10.6	5812	14990	27.5	3300	62.5	0.809	M2091	HJ12	HC12	Ø30-Ø304
N-212A8	Ø91	23	10.6	5812	14990	27.5	3300	59.5	0.770	M2091	HJ12	HC12	Ø30-Ø304
N-212A11	Ø91	23	10.6	5812	14990	27.5	3300	69.9	0.912	M2091	HJ12	HC12	Ø30-Ø304
N-215A8	Ø117.5	23	10.6	7240	18355	23.5	2500	125	2.255	M2511	HJ15	HC15	Ø50-Ø381
N-215A11	Ø117.5	23	10.6	7240	18355	23.5	2500	118	2.241	M2511	HJ15	HC15	Ø50-Ø381
N-215A15	Ø117.5	23	10.6	7240	18355	23.5	2500	138	2.822	M2511	HJ15	HC15	Ø50-Ø381
N-218A8	Ø117.5	23	10.6	7240	18355	23.5	2000	146	3.961	M2511	HJ15	HC15	Ø50-Ø450
N-218A11	Ø117.5	23	10.6	7240	18355	23.5	2000	138	3.744	M2511	HJ15	HC15	Ø50-Ø450
N-218A15	Ø117.5	23	10.6	7240	18355	23.5	2000	191	5.183	M2511	HJ15	HC15	Ø50-Ø450
N-220A11	Ø180	23	10.6	9177	23861	30.6	1800	215	7.355	ML2816	HJ24-1	HC24-1	Ø120-Ø510
N-220A15	Ø180	23	10.6	9177	23861	30.6	1800	202	6.910	ML2816	HJ24-1	HC24-1	Ø120-Ø510
N-224A11	Ø205	26	12	9177	23861	26.5	1400	332	18.199	ML3320	HJ24-1	HC24-1	Ø150-Ø610
N-224A15	Ø205	26	12	9177	23861	26.5	1400	317	17.376	ML3320	HJ24-1	HC24-1	Ø150-Ø610
N-224A20	Ø205	26	12	9177	23861	26.5	1400	286	15.677	ML3320	HJ24-1	HC24-1	Ø150-Ø610
N-232A11	Ø230	34	18	10197	24472	29.5	1200	530	43	ML3320	HJ24-1	HC24-1	Ø210-Ø800
N-232A15	Ø230	34	18	10197	24472	29.5	1200	515	43	ML3320	HJ24-1	HC24-1	Ø210-Ø800
N-232A20	Ø230	34	18	10197	24472	29.5	1200	485	42	ML3320	HJ24-1	HC24-1	Ø210-Ø800

UNIT : mm

DIM Model	A	B	C (H6)	D	E	F	G	H	J	K	L	M	N max.	O max.	O min.	P max.	P min.	Q	R	S	T	U max.	V	W	X	Y	Reference
N-205A4	135	71	110	14	15	63.513	96	82.55	15.5	3-M10	33	4	26.5	19.75	7.75	16	6	2	10	20	25	M40x1.5	3-M6	45	31	54	Fig-1
N-205A5	135	88	110	14	32	82.563	82.55	104.78	14	3-M10	33	4	26.5	19.75	7.75	33	23	2	10	20	25	M40x1.5	6-M10	45	31	54	Fig-3
N-206A4	169	96	140	20	20	63.513	104.78	82.55	16	6-M10	45	5	32	22.75	9.25	31	19	2	12	19	31	M55x2	6-M10	60	37	73	Fig-2
N-206A5	169	91	140	20	15	82.563	116	104.78	16	6-M10	45	5	32	22.75	9.25	26	14	2	12	19	31	M55x2	3-M6	60	37	73	Fig-1
N-206A6	169	111	140	20	35	106.375	104.78	133.35	16	6-M10	45	5	32	22.75	9.25	46	34	2	12	19	31	M55x2	6-M12	60	37	73	Fig-3
N-208A5	210	109	170	25	23	82.563	133.35	104.78	14	6-M12	52	5	38.7	29.75	11.75	37.5	21.5	2	14	20.5	35	M60x2	6-M10	66	38	95	Fig-2
N-208A6	210	103	170	25	17	106.375	150	133.35	18	6-M12	52	5	38.7	29.75	11.75	31.5	15.5	2	14	20.5	35	M60x2	3-M6	66	38	95	Fig-1
N-208A8	210	126	170	25	40	139.719	133.35	171.45	24	6-M12	52	5	38.7	29.75	11.75	54.5	38.5	2	14	20.5	35	M60x2	6-M16	66	38	95	Fig-3
N-210A6	254	120	220	30	25	106.375	171.45	133.35	18	6-M16	75	5	51	33.75	14.25	33.5	14.5	2	16	25	40	M85x2	6-M12	94	43	110	Fig-2
N-210A8	254	113	220	30	18	139.719	190	171.45	24	6-M16	75	5	51	33.75	14.25	26.5	7.5	2	16	25	40	M85x2	3-M8	94	43	110	Fig-1
N-210A11	254	145	220	30	50	196.869	171.45	235	28	6-M16	75	5	51	33.75	14.25	58.5	39.5	2	16	25	40	M85x2	6-M20	94	43	110	Fig-3
N-212A6	304	129	220	30	25	106.375	171.45	133.35	18	6-M16	91	6	61.3	45.75	15.75	33	10	2	21	28	50	M100x2	6-M12	108	51	130	Fig-2
N-212A8	304	122	220	30	18	139.719	190	171.45	25	6-M16	91	6	61.3	45.75	15.75	26	3	2	21	28	50	M100x2	3-M8	108	51	130	Fig-1
N-212A11	304	154	220	30	50	196.869	171.45	235	28	6-M16	91	6	61.3	45.75	15.75	58	35	2	21	28	50	M100x2	6-M20	108	51	130	Fig-3
N-215A8	381	160	300	43	33	139.719	235	171.45	24	6-M20	117.5	6	82	45.25	15.25	40	17	5	22	43	62	M130x2	6-M16	139	66	165	Fig-2
N-215A11	381	149	300	43	22	196.869	260	235	28	6-M20	117.5	6	82	45.25	15.25	29	6	5	22	43	62	M130x2	3-M20	139	66	165	Fig-1
N-215A15	381	184	300	43	57	285.775	235	330.2	29	6-M20	117.5	6	82	45.25	15.25	64	41	5	22	43	62	M130x2	6-M24	139	66	165	Fig-3
N-218A8	450	160	300	43	33	139.719	235	171.45	24	6-M20	117.5	6	82	79.75	15.25	40	6	5	22	43	62	M130x2	6-M16	139	66	165	Fig-2
N-218A11	450	149	300	43	22	196.869	260	235	28	6-M20	117.5	6	82	79.75	15.25	29	6	5	22	43	62	M130x2	3-M10	139	66	165	Fig-1
N-218A15	450	184	300	43	57	285.775	235	330.2	29	6-M20	117.5	6	82	79.75	15.25	64	41	5	22	43	62	M130x2	6-M24	139	66	165	Fig-3
N-220A11	510	169	380	60	41	196.869	330.2	235	30	6-M24	180	6	112.5	60.5	24.5	52	29	5	25	38	64	M190x3	6-M20	206	73	180	Fig-2
N-220A15	510	155	380	60	27	285.775	330.2	330.2	33	6-M24	180	6	112.5	60.5	24.5	38	15	5	25	38	64	M190x3	3-M12	206	73	180	Fig-1
N-224A11	610	186	520	60	45	196.869	463.6	235	28	6-M24	205	6	139.9	87.5	24.5	61	35	5	25	38	64	M215x3	6-M20	230	73	180	Fig-2
N-224A15	610	183	520	60	42	285.775	463.6	330.2	32.5	6-M24	205	6	139.9	87.5	24.5	58	32	5	25	38	64	M215x3	6-M24	230	73	180	Fig-2
N-224A20	610	166	520	60	25	412.775	463.6	463.6	35	6-M24	205	6	139.9	87.5	24.5	41	15	5	25	38	64	M215x3	3-M10	230	73	180	Fig-1
N-232A11	800	189	520	60	45	196.869	463.6	235	28	6-M24	230	6	162	153.5	24.5	61	27	5	25	38	64	M250x3	6-M20	262	73	180	Fig-2
N-232A15	800	186	520	60	42	285.775	463.6	330.2	32.5	6-M24	230	6	162	153.5	24.5	58	24	5	25	38	64	M250x3	6-M24	262	73	180	Fig-2
N-232A20	800	169	520	60	25	412.775	463.6	463.6	35	6-M24	230	6	162	153.5	24.5	41	7	5	25	38	64	M250x3	3-M10	262	73	180	Fig-1

NT-200

2-jaw through-hole power chuck (adapter excluded)



1. All sliding surfaces are hardened and ground for accurate actual running and long service repeatability. Lubrication nipple in each base jaw.
2. Base jaw : 1.5mmx60° serration.
3. Mounting : Adaptor mounting to fit with DIN, ISO, BS, ASA B5.9 type A spindles.

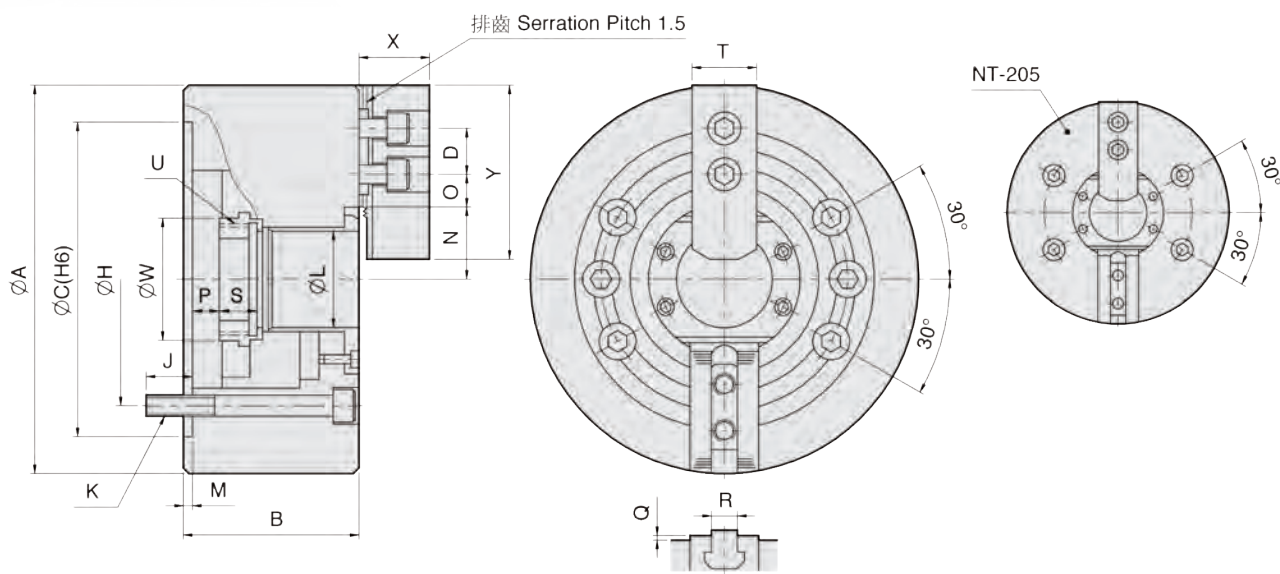

UNIT : mm

SPEC Model	Through-Hole (mm)	Plunger Stroke (mm)	Jaw Stroke (In Dia.) (mm)	Max. Pull Force (kgf)	Max. Gripping Force (kgf)	Max. Operating Pressure (kgf / cm ²)	Max. Speed (r.p.m.)	Weight (kg)	Moment Of Inertia I (kg · m ²)	Matching Cylinder	Matching Hard Jaw	Matching Soft Jaw	Gripping O.D. Range (mm)
NT-205	Ø33	10	5.4	1189	2447	19.5	7000	6.8	0.017	M1036	HJ05	HC05	Ø6-Ø135
NT-206	Ø45	12	5.5	1495	3875	18.9	6000	12.8	0.054	M1246	HJ06	HC06	Ø15-Ø169
NT-208	Ø52	16	7.4	2366	5975	18.4	5000	22	0.163	M1552	HJ08	HC08	Ø20-Ø210
NT-210	Ø75	19	8.8	2927	7546	18.4	4200	34	0.306	M1875	HJ10	HC10	Ø25-Ø254
NT-212	Ø91	23	10.6	3875	9993	18.4	3300	55	0.717	M2091	HJ12	HC12	Ø30-Ø304
NT-215	Ø117.5	23	10.6	4823	12236	15.3	2500	106	2.17	M2511	HJ15	HC15	Ø50-Ø381
NT-218	Ø117.5	23	10.6	4823	12236	15.3	2000	122	3.31	M2511	HJ15	HC15	Ø50-Ø450

DIM Model	A	B	C (H6)	D	H	J	K	L	M	N max.	O max.	O min.	P max.	P min.	Q	R	S	T	U max.	W	X	Y
NT-205	135	60	110	14	82.55	15	4-M10x60	33	4	26.5	19.75	7.75	1	-9	2	10	20	23	M40x1.5	45	31	54
NT-206	169	81	140	20	104.78	16	6-M10x80	45	5	32	22.75	9.25	11	-1	2	12	19	31	M55x2	60	37	73
NT-208	210	91	170	25	133.35	20	6-M12x90	52	5	38.7	29.75	11.75	14.5	-1.5	2	14	20.5	35	M60x2	66	38	95
NT-210	254	100	220	30	171.45	22	6-M16x100	75	5	51	33.75	14.25	8.5	-10.5	2	16	25	40	M85x2	94	43	110
NT-212	304	110	220	30	171.45	23	6-M16x110	91	6	61.3	45.75	15.75	8	-15	2	21	28	50	M100x2	108	51	130
NT-215	381	133	300	43	235	30	6-M20x135	117.5	6	82	45.25	15.25	7	-16	5	22	43	62	M130x2	139	66	165
NT-218	450	133	300	43	235	30	6-M20x135	117.5	6	82	79.75	15.25	7	-16	5	22	43	62	M130x2	139	66	165

NIT-200

4-jaw through-hole power chuck (adapter excluded)



1. All sliding surfaces are hardened and ground for accurate actual running and long service repeatability. Lubrication nipple in each master jaw.
2. Master jaw : 1.5mmx60° serration.
3. Mounting : Adaptor mounting to fit with DIN, ISO, BS, ASA B5.9 type A spindles.

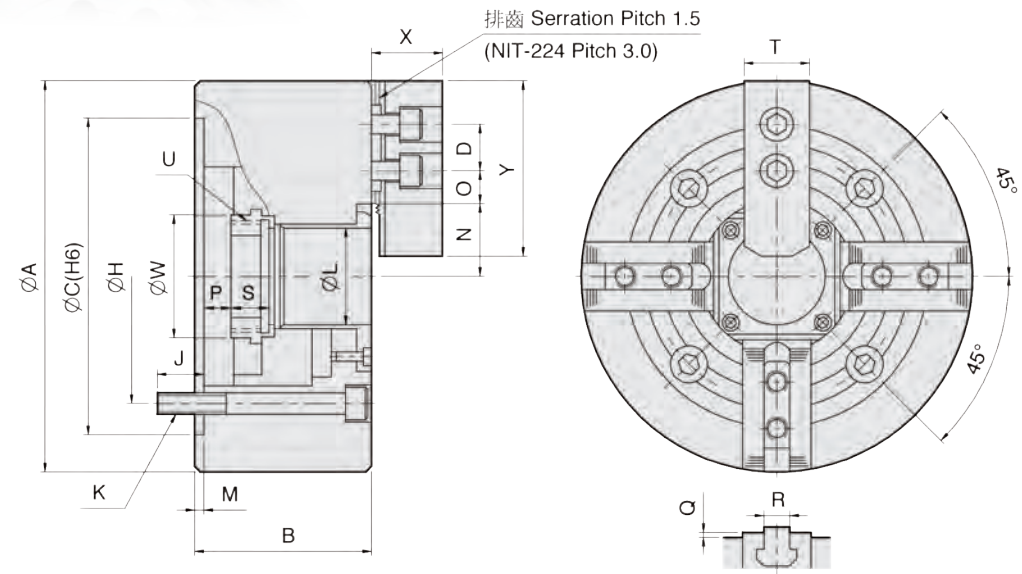

UNIT : mm

SPEC Model	Through-Hole (mm)	Plunger Stroke (mm)	Jaw Stroke (In Dia.) (mm)	Max. Pull Force (kgf)	Max. Gripping Force (kgf)	Max. Operating Pressure (kgf / cm ²)	Max. Speed (r.p.m.)	Weight (kg)	Moment Of Inertia I (kg · m ²)	Matching Cylinder	Matching Hard Jaw	Matching Soft Jaw	Gripping O.D. Range (mm)
NIT-206	Ø45	12	5.5	2243	5812	28.5	4500	13.7	0.058	M1246	HJ06	HC06	Ø15-Ø169
NIT-208	Ø52	16	7.4	3558	9075	26.5	3600	24	0.177	M1552	HJ08	HC08	Ø20-Ø210
NIT-210	Ø75	19	8.8	4385	11319	27.5	3200	36	0.324	M1875	HJ10	HC10	Ø25-Ø254
NIT-212	Ø91	23	10.6	5812	14990	27.5	2700	58.5	0.763	M2091	HJ12	HC12	Ø30-Ø304
NIT-215	Ø117.5	23	10.6	7240	18355	23.5	1900	114	2.331	M2511	HJ15	HC15	Ø50-Ø381
NIT-218	Ø117.5	23	10.6	7240	18355	23.5	1500	140	3.798	M2511	HJ15	HC15	Ø50-Ø450
NIT-224	Ø205	26	12	9177	23861	26.5	1000	284	15.2	ML3320	HJ24-1	HC24-1	Ø150-Ø610

DIM Model	A	B	C (H6)	D	H	J	K	L	M	N max.	O max.	O min.	P max.	P min.	Q	R	S	T	U max.	W	X	Y
NIT-206	169	81	140	20	104.78	16	4-M10x80	45	5	32	22.75	9.25	11	-1	2	12	19	31	M55x2	60	37	73
NIT-208	210	91	170	25	133.35	20	4-M12x90	52	5	38.7	29.75	11.75	14.5	-1.5	2	14	20.5	35	M60x2	66	38	95
NIT-210	254	100	220	30	171.45	22	4-M16x100	75	5	51	33.75	14.25	8.5	-10.5	2	16	25	40	M85x2	94	43	110
NIT-212	304	110	220	30	171.45	23	4-M16x110	91	6	61.3	45.75	15.75	8	-15	2	21	28	50	M100x2	108	51	130
NIT-215	381	133	300	43	235	30	4-M20x135	117.5	6	82	45.25	15.25	7	-16	5	22	43	62	M130x2	139	66	165
NIT-218	450	133	300	43	235	30	4-M20x135	117.5	6	82	79.75	15.25	7	-16	5	22	43	62	M130x2	139	66	165
NIT-224	610	147	520	60	463.6	35	8-M24x150	205	6	139.9	87.5	24.5	16	-10	5	25	38	64	M215x3	230	73	180



NHT-200

2-jaw and 3-jaw through-hole power chuck (adapter included)

1. Gripping of round or irregular workpiece does not need to change the chuck.
2. The chucks are designed according to ASA B5.9 type A spindle.
3. The chucks are made from high grade alloy steel. All sliding surfaces are hardened and ground to increase running accuracy and longer service life.



NB-200A

3-jaw extra large through-hole power chuck (adapter included)

1. More large bore:
The largest bore in wedge type power operated chucks.
2. 20% large bore:
Approximately 20% higher speed, higher gripping force and larger bore compared with regular chucks.
3. Model NB-200A chucks are assembled with adaptor for ASA B5.9 type A spindles.
4. Model NB-200A chucks are manufactured from high grade alloy steel. All sliding surfaces are hardened and ground for accurate actual running and long service repeatability.

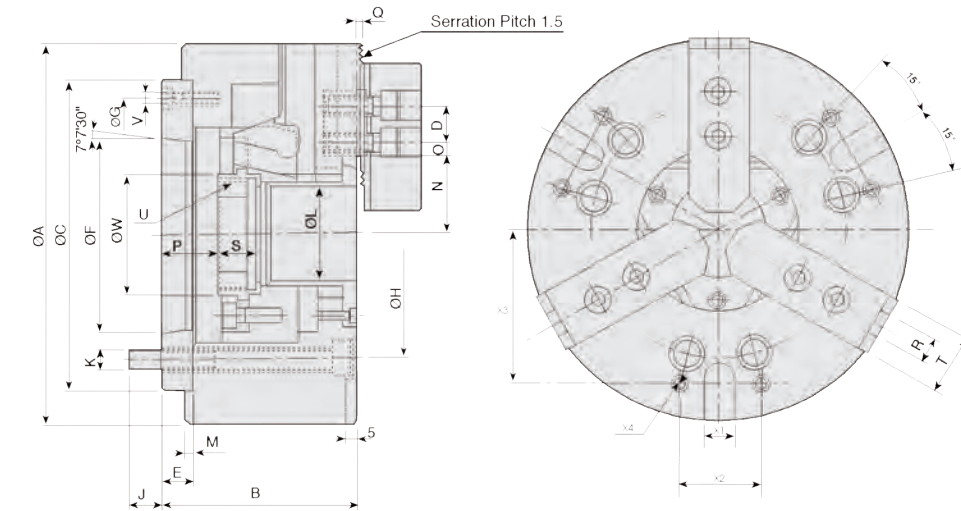
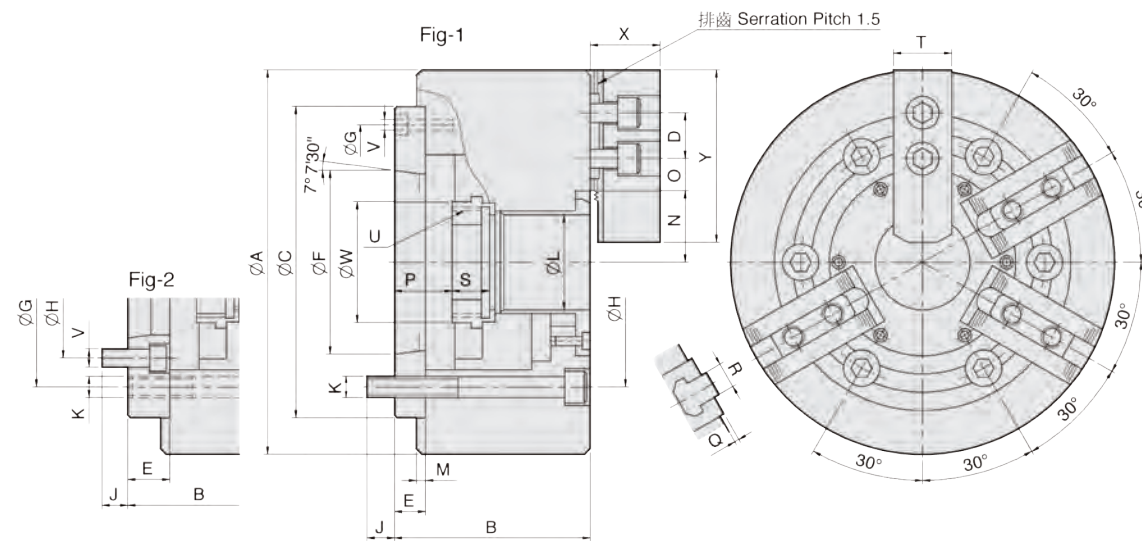

UNIT : mm

SPEC Model	Through-Hole (mm)	Plunger Stroke (mm)	Jaw Stroke (In Dia.) (mm)	Max. Pull Force (kgf)	Max. Gripping Force (kgf)	Max. Operating Pressure (kgf/cm ²)	Max. Speed (r.p.m.)	Weight (kg)	Moment Of Inertia I (kg·m ²)	Matching Cylinder	Matching Hard Jaw	Matching Soft Jaw	Gripping O.D. Range (mm)
NB-306A5	Ø52	12	5.4	2243	5812	18.4	6000	14	0.06	M1552	HJ06	HC06	Ø16-Ø170
NB-208A6	Ø66	16	7.4	3558	9075	20.5	5000	24	0.14	M1868	HJ08	HC08	Ø20-Ø210
NB-210A8	Ø78	19	8.8	4385	11319	27.5	4200	37.4	0.4	M1878	HJ10	HC10	Ø25-Ø254
NB-310A8	Ø81	19	8.8	4976	12848	31.5	4500	36.4	0.33	MK1881	HJ10	HC10	Ø37-Ø254
NB-212A11	Ø122	23	10.6	5812	14990	20.5	3200	65	0.95	M2511	HJ12	HC12	Ø41-Ø315
NB-215A15	Ø142	23	10.6	7240	18355	25.5	2500	130	3.0	ML2816	HJ15	HC15	Ø60-Ø405
NB-218A15	Ø166.5	23	10.6	7240	18355	25.5	2000	161	4.77	ML2816	HJ15	HC15	Ø75-Ø457

UNIT : mm

SPEC Model	Through-Hole (mm)	Plunger Stroke (mm)	Jaw Stroke (In Dia.) (mm)	Max. Pull Force (kgf)	Max. Gripping Force (kgf)	Max. Operating Pressure (kgf/cm ²)	Max. Speed (r.p.m.)	Weight (kg)	Matching Cylinder	Matching Hard Jaw	Matching Soft Jaw
NHT-208A5	Ø52	16	7.4	2243 / 1495	5812 / 3875	17.2 / 12.1	3500	25.5	M1552	HJ06	HC08-1
NHT-208A6	Ø52	16	7.4	2243 / 1495	5812 / 3875	17.2 / 12.1	3500	24.7	M1552	HJ06	HC08-1

DIM Model	A	B	C (H6)	D	E	F	G	H	J	K	L	M	N	O	P	Q	R	S	T	U	V	W	X	Y	Reference		
NHT-208A5	210	113	170	20	23	82.563	133.35	104.78	13	6xM12	52	5	41.8	34	7.5	37.5	21.5	2	12	20.5	35	M60x2	6xM10	66	37	73	Fig-2
NHT-208A6	210	107	170	20	17	106.375	150	133.35	17	6xM12	52	5	41.8	34	7.5	31.5	15.5	2	12	20.5	35	M60x2	3xM6	66	37	73	Fig-1

DIM Model	A	B	C (H6)	D	E	F	G	H	J	K	L	M	N	O	P	Q	R	S	T	U	V	W	X1 (H12)	X2	X3	X4		
NB-306A5	170	91	140	20	15	82.563	116	104.78	14.5	6xM10	52	5	34.3	18.25	9.25	26	14	2	12	20	31	M60x2	3xM6	65	16	36	65	M8
NB-208A6	210	103	170	25	17	106.375	150	133.35	19.5	6xM12	66	5	42	23.75	11.75	31.5	15.5	2	14	20	35	M75x2	3xM6	80	16	45	80	M8
NB-210A8	254	113	220	30	18	139.719	190	171.45	24	6xM16	78	5	53	33.75	14.25	26.5	7.5	2	16	25	40	M87x2	3xM8	94	16	60	102	M10
NB-310A8	254	113	220	30	18	139.719	190	171.45	24	6xM16	81	5	54	32.25	14.25	26.5	7.5	2	16	25	40	M90x2	3xM8	97	16	60	102	M10
NB-212A11	315	134	300	30	22	196.869	260	235	28	6xM20	122	6	74.2	36.25	12.75	42	19	2	21	28	50	M135x2	3xM10	143	20	60	138	M10
NB-215A15	405	154	380	43	27	285.775	330.2	330.2	33	6xM24	142	6	93.5	45.25	15.25	34	11	5	22	43	62	M155x2	3xM12	164	20	80	160	M12
NB-218A15	457	154	380	43	27	285.775	330.2	330.2	33	6xM24	166.5	6	96.7	63.25	18.25	34	11	5	22	43	62	M180x3	3xM12	189	20	100	160	M12



V

3-jaw wedge type non through-hole power chuck (adapter excluded)

- High performance :
Similar high performance with N series.
- Chuck mounting screws :
Metric or UNC socket head cap screws are supplied for installing the chuck to the spindle.

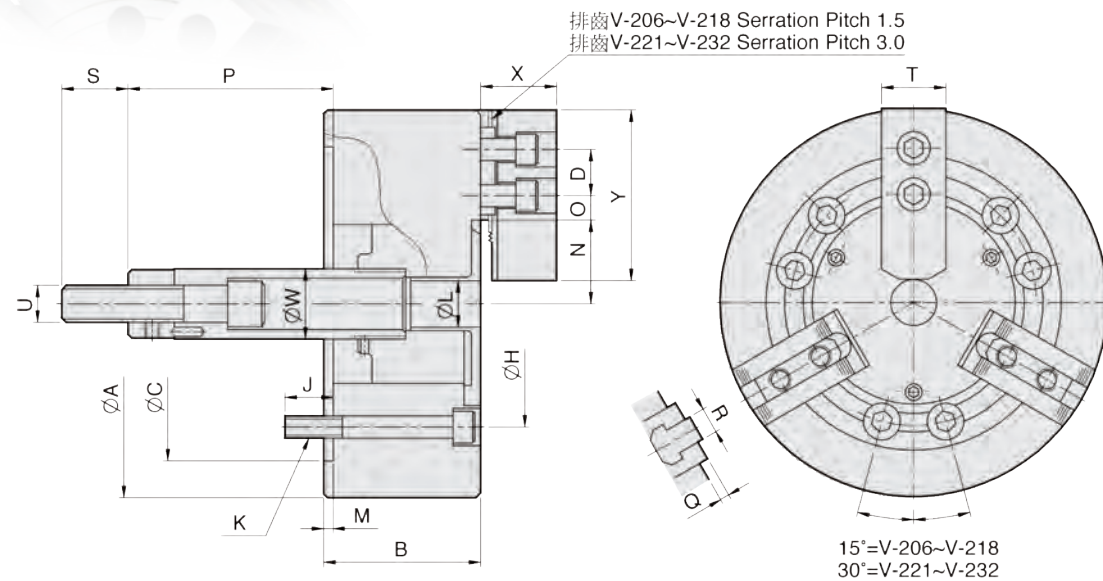

UNIT : mm

SPEC Model	Plunger Stroke (mm)	Jaw Stroke (In Dia.) (mm)	Max. Pull Force (kgf)	Max. Gripping Force (kgf)	Max. Operating Pressure (kgf / cm ²)	Max. Speed (r.p.m.)	Weight (kg)	Moment Of Inertia I (kg · m ²)	Matching Cylinder	Matching Hard Jaw	Matching Soft Jaw	Gripping O.D. Range (mm)
V-206	20	9.2	1835	5353	26.5	5200	12.7	0.048	MS105C	HJ06	HC06	Ø18-Ø165
V-208	21	9.7	2549	7648	25.5	4500	23.8	0.137	MS125C	HJ08	HC08	Ø26-Ø210
V-210	25	8.8	2957	11013	28.6	4000	36.4	0.3	MS125C	HJ10	HC10	Ø26-Ø254
V-212	30	10.5	4181	15907	27.5	3300	62.3	0.78	MS150C	HJ12-1	HC12-1	Ø26-Ø304
V-215	35	16	8362	25391	32.6	3000	106	1.94	MS200C	HJ15-1	HC15-1	Ø68-Ø381
V-218	35	16	8362	25391	32.6	2700	122	3.09	MS200C	HJ15-1	HC15-1	Ø98-Ø450

DIM Model	A	B	C	D	H	J	K	L	M	N max.	O max.	O min.	P max.	P min.	Q	R	S	T	U	W	X	Y
V-206	165	74	140	20	104.78	14	6-M10x70	21	5	38.7	15.25	7.75	104.6	84.6	4	12	36	31	M16x2.0	34	39	73
V-208	210	85	170	25	133.35	20	6-M12x85	25	5	46.75	22.25	8.75	132	111	5	14	36	35	M20x2.5	38	41	95
V-210	254	89	220	30	171.45	18	6-M16x85	34	5	51.1	30.75	9.75	158	133	5	16	36	40	M20x2.5	45	46	110
V-212	304	106	220	30	171.45	23	6-M16x105	34	6	61	48.75	9.75	163	133	5	18	36	50	M20x2.5	50	54	130
V-215	381	114	300	43	235	29	6-M20x115	—	6	77.5	49.75	21.25	104	69	2	25.5	55	62	M30x3.5	60	63	165
V-218	450	114	300	43	235	29	6-M20x115	—	6	108	49.75	21.25	92	57	2	25.5	55	62	M30x3.5	60	63	165



VT&VIT

2-jaw and 4-jaw wedge type non through-hole power chuck (adapter excluded)

- Suitable for special applications :
Used to hold special shape work pieces, such as square bar or flanges which is not possible clamping by 3 jaw chuck.
- Interchangeable with V or VA series.
- Basic dimensions are the same as V type.
- High performance as V type.

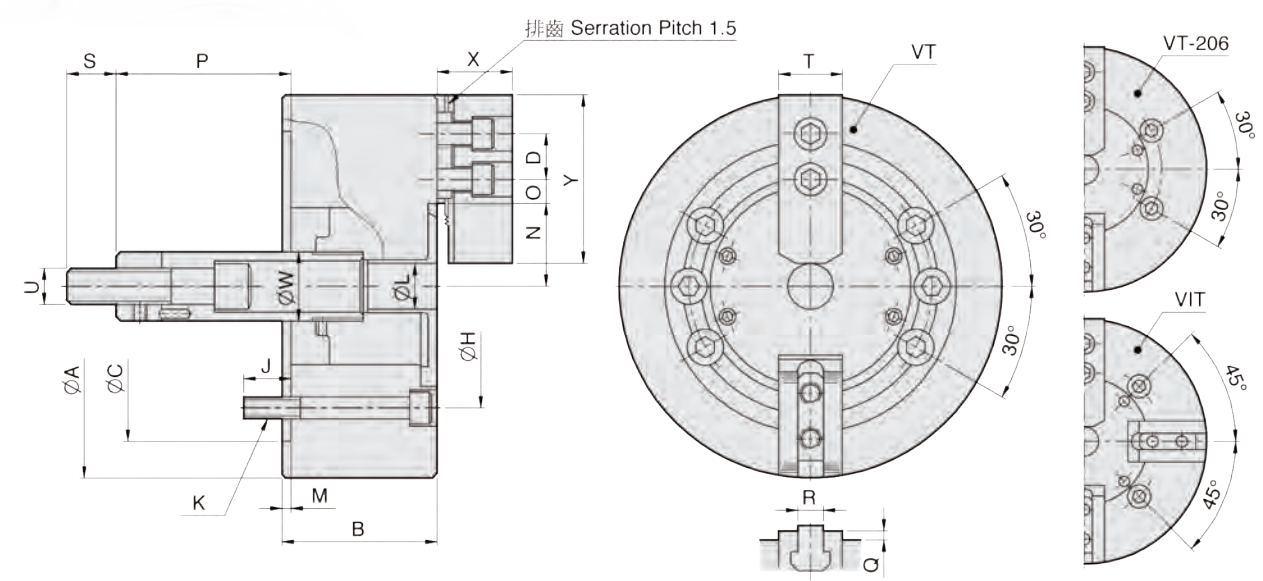

UNIT : mm

SPEC Model	Jaws	Plunger Stroke (mm)	Jaw Stroke (In Dia.) (mm)	Max. Pull Force (kgf)	Max. Gripping Force (kgf)	Max. Operating Pressure (kgf / cm ²)	Max. Speed (r.p.m.)	Weight (kg)	Moment Of Inertia I (kg · m ²)	Matching Cylinder	Matching Hard Jaw	Matching Soft Jaw	Gripping O.D. Range (mm)
VT-206	2	20	9.2	1224	3569	17.3	5200	12.3	0.045	MS105C	HJ06	HC06	Ø18-Ø165
VT-208	2	21	9.7	1683	5098	16.3	4500	23.1	0.13	MS125C	HJ08	HC08	Ø26-Ø210
VT-210	2	25	8.8	1988	7342	19.4	4000	35.1	0.29	MS125C	HJ10	HC10	Ø26-Ø254
VT-212	2	30	10.5	2804	10605	18.4	3300	60.3	0.7	MS150C	HJ12-1	HC12-1	Ø26-Ø304
VIT-212	4	30	10.5	4181	15907	27.5	2800	64.3	0.77	MS150C	HJ12-1	HC12-1	Ø26-Ø304
VT-215	2	35	16	5557	16927	21.7	3000	102.6	1.89	MS200C	HJ15-1	HC15-1	Ø68-Ø381
VIT-218	4	35	16	8362	25391	32.6	2300	127	3.21	MS200C	HJ15-1	HC15-1	Ø98-Ø450

DIM Model	A	B	C	D	H	J	K	L	M	N max.	O max.	O min.	P max.	P min.	Q	R	S	T	U	W	X	Y
VT-206	165	74	140	20	104.78	14	4-M10x70	21	5	38.7	15.25	7.75	104.6	84.6	4	12	36	31	M16x2.0	34	39	73
VT-208	210	85	170	25	133.35	20	6-M12x85	25	5	46.75	22.25	8.75	132	111	5	14	36	35	M20x2.5	38	41	95
VT-210	254	89	220	30	171.45	18	6-M16x85	34	5	51.1	30.75	9.75	158	133	5	16	36	40	M20x2.5	45	46	110
VT-212	304	106	220	30	171.45	23	6-M16x105	34	6	61	48.75	9.75	163	133	5	18	36	50	M20x2.5	50	54	130
VIT-212	304	106	220	30	171.45	23	4-M16x105	34	6	61	48.75	9.75	163	133	5	18	36	50	M20x2.5	50	54	130
VT-215	381	114	300	43	235	29	6-M20x115	—	6	77.5	49.75	21.25	104	69	2	25.5	55	62	M30x3.5	60	63	165
VIT-218	450	114	300	43	235	29	4-M20x115	—	6	108	49.75	21.25	92	57	2	25.5	55	62	M30x3.5	60	63	165



VA

3-jaw wedge type non through-hole power chuck (adapter included)

1. High performance :
Similar high performance with N series.
2. Chuck mounting screws :
Metric or UNC socket head cap screws are supplied for installing the chuck to the spindle.
3. Alternative spindle adaptors :
ASA or DIN adaptors can be supplied as requested.

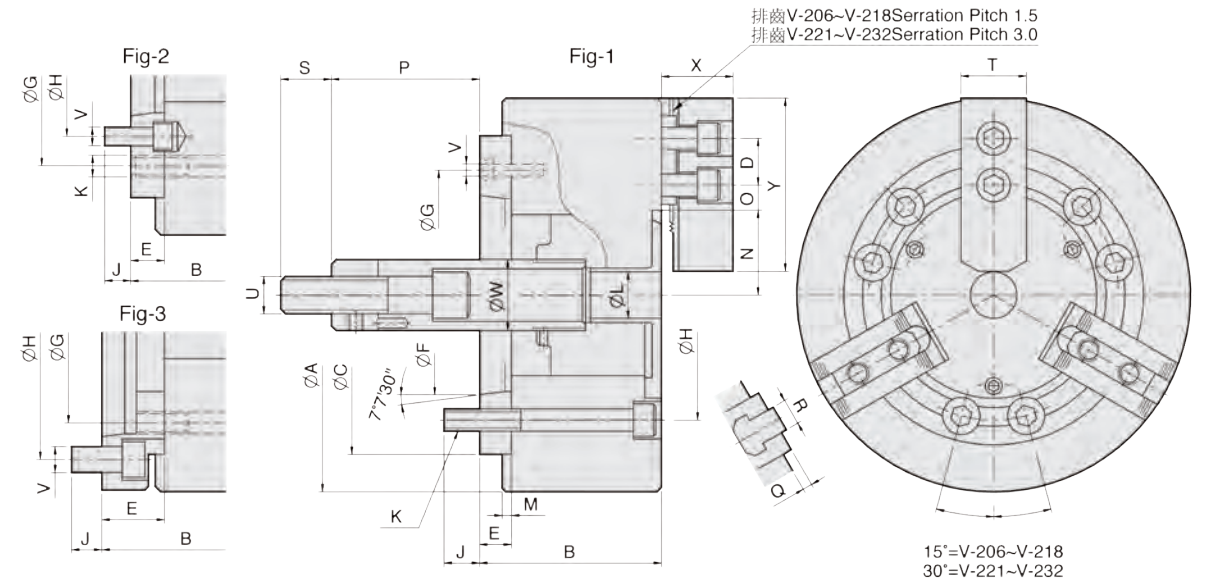

UNIT : mm

SPEC Model	Plunger Stroke (mm)	Jaw Stroke (In Dia.) (mm)	Max. Pull Force (kgf)	Max. Gripping Force (kgf)	Max. Operating Pressure (kgf / cm ²)	Max. Speed (r.p.m.)	Weight (kg)	Moment Of Inertia I (kg · m ²)	Matching Cylinder	Matching Hard Jaw	Matching Soft Jaw	Gripping O.D. Range (mm)
V-206A4	20	9.2	1835	5353	26.5	5200	14.5	0.062	MS105C	HJ06	HC06	Ø18-Ø165
V-206A5	20	9.2	1835	5353	26.5	5200	13.9	0.056	MS105C	HJ06	HC06	Ø18-Ø165
V-206A6	20	9.2	1835	5353	26.5	5200	15.8	0.059	MS105C	HJ06	HC06	Ø18-Ø165
V-208A5	21	9.7	2549	7648	25.5	4500	26.8	0.154	MS125C	HJ08	HC08	Ø26-Ø210
V-208A6	21	9.7	2549	7648	25.5	4500	25.6	0.147	MS125C	HJ08	HC08	Ø26-Ø210
V-208A8	21	9.7	2549	7648	25.5	4500	30	0.172	MS125C	HJ08	HC08	Ø26-Ø210
V-210A6	25	8.8	2957	11013	28.6	4000	41.8	0.35	MS125C	HJ10	HC10	Ø26-Ø254
V-210A8	25	8.8	2957	11013	28.6	4000	39.6	0.33	MS125C	HJ10	HC10	Ø26-Ø254
V-210A11	25	8.8	2957	11013	28.6	4000	50	0.417	MS125C	HJ10	HC10	Ø26-Ø254
V-212A6	30	10.5	4181	15907	27.5	3300	67.6	0.76	MS150C	HJ12-1	HC12-1	Ø26-Ø304
V-212A8	30	10.5	4181	15907	27.5	3300	65.5	0.75	MS150C	HJ12-1	HC12-1	Ø26-Ø304
V-212A11	30	10.5	4181	15907	27.5	3300	75.9	0.888	MS150C	HJ12-1	HC12-1	Ø26-Ø304
V-215A8	35	16	8362	25391	32.6	3000	119	2.12	MS200C	HJ15-1	HC15-1	Ø68-Ø381
V-215A11	35	16	8362	25391	32.6	3000	113	2.05	MS200C	HJ15-1	HC15-1	Ø68-Ø381
V-215A15	35	16	8362	25391	32.6	3000	132	2.56	MS200C	HJ15-1	HC15-1	Ø68-Ø381
V-218A8	35	16	8362	25391	32.6	2700	136	3.28	MS200C	HJ15-1	HC15-1	Ø98-Ø450
V-218A11	35	16	8362	25391	32.6	2700	129	3.20	MS200C	HJ15-1	HC15-1	Ø98-Ø450
V-218A15	35	16	8362	25391	32.6	2700	148	3.71	MS200C	HJ15-1	HC15-1	Ø98-Ø450

UNIT : mm

DIM Model	A	B	C (H6)	D	E	F	G	H	J	K	L	M	N max.	O max.	O min.	P max.	P min.	Q	R	S	T	U	V	W	X	Y	Reference
V-206A4	165	89	140	20	20	63.513	104.78	82.55	16	6-M10	21	5	38.7	15.25	7.75	84.6	64.6	4	12	36	31	M16x2.0	6-M10	34	39	73	Fig2
V-206A5	165	84	140	20	15	82.563	116	104.78	14	6-M10	21	5	38.7	15.25	7.75	89.6	69.6	4	12	36	31	M16x2.0	3-M6	34	39	73	Fig1
V-206A6	165	104	140	20	35	106.375	104.78	133.35	16	6-M10	21	5	38.7	15.25	7.75	69.6	49.6	4	12	36	31	M16x2.0	6-M12	34	39	73	Fig3
V-208A5	210	103	170	25	23	82.563	133.35	104.78	14	6-M12	25	5	46.75	22.25	8.75	109	88	5	14	36	35	M20x2.5	6-M10	38	41	95	Fig2
V-208A6	210	97	170	25	17	106.375	150	133.35	18	6-M12	25	5	46.75	22.25	8.75	115	94	5	14	36	35	M20x2.5	3-M6	38	41	95	Fig1
V-208A8	210	120	170	25	40	139.719	133.35	171.45	24	6-M12	25	5	46.75	22.25	8.75	92	71	5	14	36	35	M20x2.5	6-M16	38	41	95	Fig3
V-210A6	254	109	220	30	25	106.375	171.45	133.35	18	6-M16	34	5	51.1	30.75	9.75	133	108	5	16	36	40	M20x2.5	6-M12	45	46	110	Fig2
V-210A8	254	102	220	30	18	139.719	190	171.45	25	6-M16	34	5	51.1	30.75	9.75	140	115	5	16	36	40	M20x2.5	3-M8	45	46	110	Fig1
V-210A11	254	134	220	30	50	196.869	171.45	235	28	6-M16	34	5	51.1	30.75	9.75	108	83	5	16	36	40	M20x2.5	6-M20	45	46	110	Fig3
V-212A6	304	125	220	30	25	106.375	171.45	133.35	18	6-M16	34	6	61	48.75	9.75	138	108	5	18	36	50	M20x2.5	6-M12	50	54	130	Fig2
V-212A8	304	118	220	30	18	139.719	190	171.45	25	6-M16	34	6	61	48.75	9.75	145	115	5	18	36	50	M20x2.5	3-M8	50	54	130	Fig1
V-212A11	304	150	220	30	50	196.869	171.45	235	28	6-M16	34	6	61	48.75	9.75	113	83	5	18	36	50	M20x2.5	6-M20	50	54	130	Fig3
V-215A8	381	141	300	43	33	139.719	235	171.45	24	6-M20	—	6	77.5	49.75	21.25	71	36	2	25.5	55	62	M30x3.5	6-M16	60	63	165	Fig2
V-215A11	381	130	300	43	22	196.869	260	235	32	6-M20	—	6	77.5	49.75	21.25	82	47	2	25.5	55	62	M30x3.5	3-M10	60	63	165	Fig1
V-215A15	381	165	300	43	57	285.775	235	330.2	29	6-M20	—	6	77.5	49.75	21.25	47	12	2	25.5	55	62	M30x3.5	6-M24	60	63	165	Fig3
V-218A8	450	141	300	43	33	139.719	235	171.45	24	6-M20	—	6	108	49.75	21.25	59	24	2	25.5	55	62	M30x3.5	6-M16	60	63	165	Fig2
V-218A11	450	130	300	43	22	196.869	260	235	32	6-M20	—	6	108	49.75	21.25	70	35	2	25.5	55	62	M30x3.5	3-M10	60	63	165	Fig1
V-218A15	450	165	300	43	57	285.775	235	330.2	29	6-M20	—	6	108	49.75	21.25	35	0	2	25.5	55	62	M30x3.5	6-M24	60	63	165	Fig3

V(40"-79")

Large wedge type non through-hole power chuck (adapter excluded)

1. Chucking operations of very large components external or internal clamping.
2. Suitable for vertical lathe, due to the front protection of slide way.
3. Master jaw with manual radial setting function.

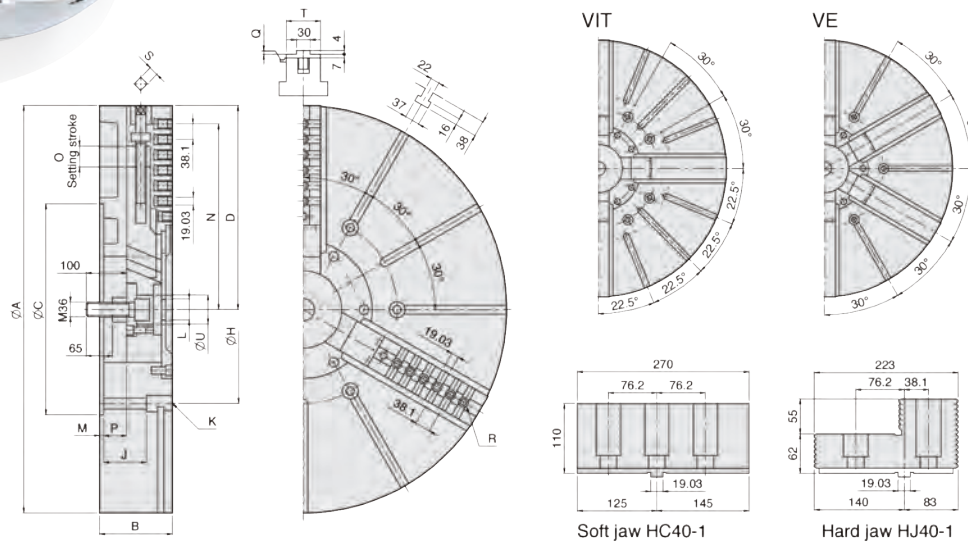

Soft jaw HC40-1 Hard jaw HJ40-1

UNIT : mm

SPEC Model	Jaws	Plunger Stroke (mm)	Radial Jaw Stroke + (Manual setting) (mm)	Max. Pull Force (kN)	Max. Gripping Force (kN)	Max. Operating Pressure (kgf / cm ²)	Max. Speed (r.p.m.)	Weight (kg)	Moment Of Inertia I (kg · m ²)	Matching Cylinder	Matching Hard Jaw	Matching Soft Jaw	Gripping O.D. Range (mm)
40" V-240	3	57	23 + (30)	180	320	42.8	630	645	82	MS250C	HJ40-1	HC40-1	Ø285-Ø1005
VIT-240	4						550	700	89				
50" V-250	3						500	890	168				
VIT-250	4	57	23 + (30)	180	320	42.8	400	940	177	MS250C	HJ40-1	HC40-1	Ø270-Ø1250
VE-250	6						360	971	183				
63" V-263	3						400	1800	548				
VIT-263	4	60	24 + (40)	200	360	46.9	300	1700	518	MS250C	HJ40-1	HC40-1	Ø390-Ø1600
VE-263	6						280	1800	548				
79" VE-279	6	60	24 + (40)	200	360	46.9	230	2850	1350	MS250C	HJ40-1	HC40-1	Ø440-Ø2000

DIM Model	A	B	C	D max.	H	J	K	L	M	N max.	O	P max.	P min.	Q	R	S	T	U
40" V-240																		
VIT-240	1005	180	520	502	463.6	108	M24	M52x1.5	8	457	30	59	2	4	7-M24	19	85	72
50" V-250																		
VIT-250	1250	180	520	623	463.6	108	M24	M52x1.5	8	563	30	59	2	4	10-M24	19	85	72
VE-250																		
63" V-263																		
VIT-263	1600	220	720	796	647.6	144	M30	M52x1.5	8	738	40	82	22	6	13-M24	22	110	72
VE-263																		
79" VE-279	2000	238	720	996	647.6	159	M30	M52x1.5	8	914	40	100	40	6	17-M24	22	110	72



DV/DN

Vertical and vertical horizontal stationary power chuck

1. Suitable for vertical milling and drilling operations.
2. With large through-hole, Vertical / horizontal power chucks does not only clamp the long workpiece but also the horizontal holding.

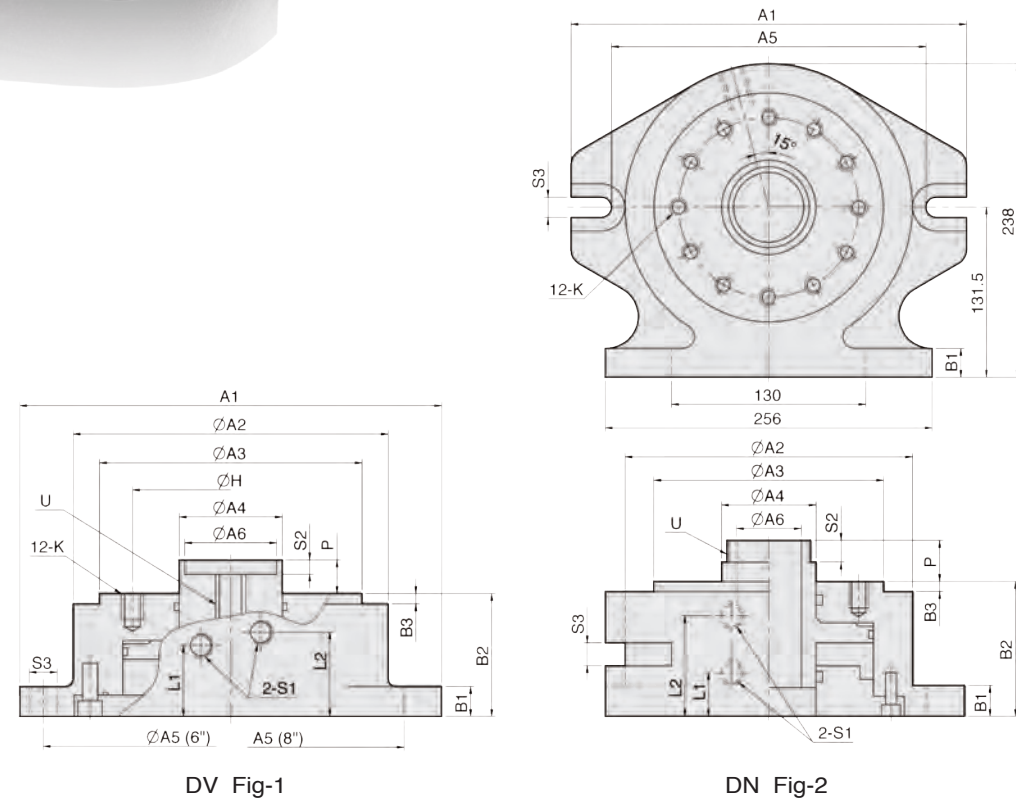

DV Fig-1

DN Fig-2

UNIT : mm

SPEC Model	Piston Dia. (mm)	Piston Area (cm ²) Push Side / Pull Side	Max. Draw Bar Force (kgf) Push Side / Pull Side	Piston Stroke (mm)	Max. Operating Pressure (kgf / cm ²)	Weight (kg)	Matching Chuck
DV-6	Ø115	104 / 78.5	1900 / 1400	20	20	12	V-206
DV-8	Ø155	187 / 148.6	3600 / 2800	21	20	21	V-208, V-210, V-212
DN-8	Ø155	148.6 / 148.6	2800 / 2800	17	20	28.5	N-208

DIM Model	A1	A2	A3	A4	A5	A6	B1	B2	B3	H	K	L1	L2	P max.	P min.	S1	S2	S3	U	Reference
DV-6	Ø220	168	140	55	Ø200	49	16	65.5	5.5	104.78	12-M10x15L	38	45	18	-2	PT 1/4"	7.6	2-Ø15	M16xP2.0	Fig-1
DV-8	290	210	170	70	242	58	24	86	5.5	133.35	12-M12x16L	23	65	20	-1	PT 1/4"	5.5	2-16	M16xP2.0	Fig-1
DN-8	293	213	170	70	242	52	24	100	5.5	133.35	12-M12x18L	32.5	74.5	30.4	13.4	PT 1/4"	16	4-17	M60xP2.0	Fig-2



VRA

Non through-hole power chuck for vertical lathe (adapter included)

1. The front protection of slide way.
2. Suitable for vertical lathe.

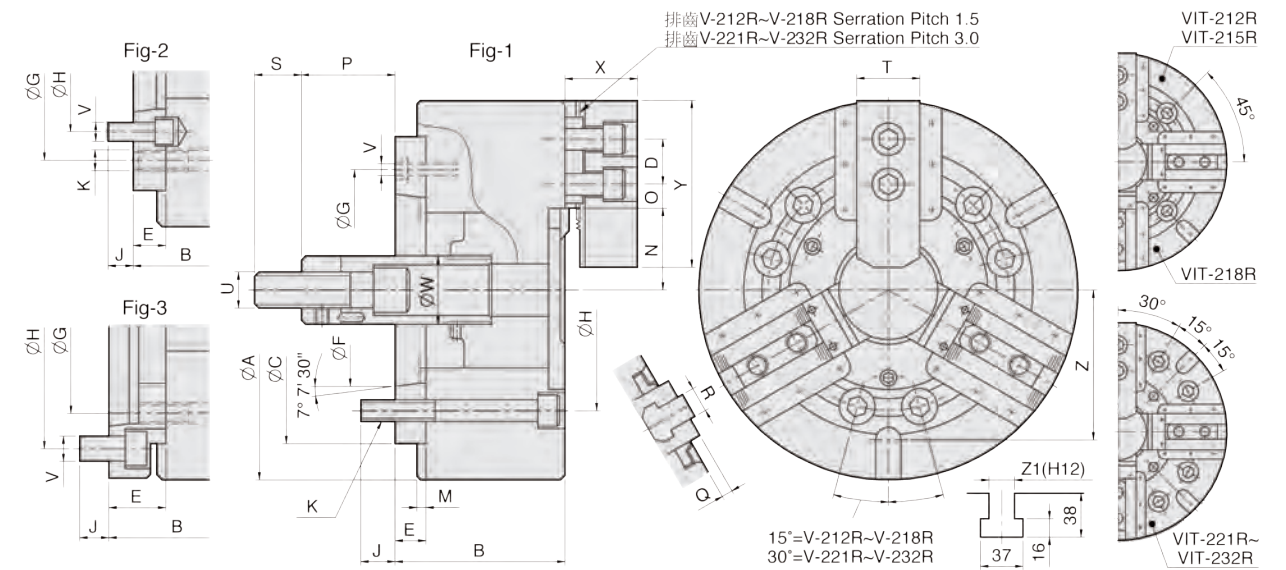

UNIT : mm

SPEC Model	Jaws	Plunger Stroke (mm)	Jaw Stroke (in Dia.) (mm)	Max. Pull Force (kgf)	Max. Gripping Force (kgf)	Max. Operating Pressure (kgf / cm ²)	Max. Speed (r.p.m.)	Weight (kg)	Moment Of Inertia I (kg · m ²)	Matching Cylinder	Matching Hard Jaw	Matching Soft Jaw	Gripping O.D. Range (mm)
V-212RA6	3	30	16	5302	14276	35.7	3000	67.7	0.774	MS150C	HJ12-1	HC12-1	Ø32-Ø304
V-212RA8	3	30	16	5302	14276	35.7	3000	65.6	0.764	MS150C	HJ12-1	HC12-1	Ø32-Ø304
V-212RA11	3	30	16	5302	14276	35.7	3000	74.1	0.902	MS150C	HJ12-1	HC12-1	Ø32-Ø304
V-215RA8	3	35	18.7	9585	25798	35.7	2800	120.4	2.146	MS200C	HJ15-1	HC15-1	Ø68-Ø381
V-215RA11	3	35	18.7	9585	25798	35.7	2800	113.4	2.016	MS200C	HJ15-1	HC15-1	Ø68-Ø381
V-215RA15	3	35	18.7	9585	25798	35.7	2800	133	2.572	MS200C	HJ15-1	HC15-1	Ø68-Ø381
V-218RA8	3	35	18.7	9585	25798	35.7	2300	144.5	3.507	MS200C	HJ15-1	HC15-1	Ø78-Ø450
V-218RA11	3	35	18.7	9585	25798	35.7	2300	137.5	3.43	MS200C	HJ15-1	HC15-1	Ø78-Ø450
V-218RA15	3	35	18.7	9585	25798	35.7	2300	157.5	3.945	MS200C	HJ15-1	HC15-1	Ø78-Ø450
V-221RA8	3	35	16	9075	28450	33.7	1940	198	6.46	MS200C	HJ24-1	HC24-1	Ø65-Ø530
V-221RA11	3	35	16	9075	28450	33.7	1940	190	6.35	MS200C	HJ24-1	HC24-1	Ø65-Ø530
V-221RA15	3	35	16	9075	28450	33.7	1940	184	6.28	MS200C	HJ24-1	HC24-1	Ø65-Ø530
V-224RA8	3	35	16	9075	28450	33.7	1760	240	10.54	MS200C	HJ24-1	HC24-1	Ø152-Ø610
V-224RA11	3	35	16	9075	28450	33.7	1760	233	10.44	MS200C	HJ24-1	HC24-1	Ø152-Ø610
V-224RA15	3	35	16	9075	28450	33.7	1760	227	10.36	MS200C	HJ24-1	HC24-1	Ø152-Ø610
V-232RA11	3	35	18.7	9585	25798	35.7	1060	390	30.9	MS200C	HJ24-1	HC32-1	Ø100-Ø810
V-232RA15	3	35	18.7	9585	25798	35.7	1060	383	30.82	MS200C	HJ24-1	HC32-1	Ø100-Ø810
V-232RA20	3	35	18.7	9585	25798	35.7	1060	419	32.69	MS200C	HJ24-1	HC32-1	Ø100-Ø810
VIT-212RA8	4	30	16	5302	14276	35.7	2500	68	0.792	MS150C	HJ12-1	HC12-1	Ø45-Ø304
VIT-218RA11	4	35	18.7	9585	25798	35.7	2000	141.5	3.522	MS200C	HJ15-1	HC15-1	Ø78-Ø450
VIT-224RA11	4	35	18.7	9075	28450	33.7	1520	255	11.3	MS200C	HJ24-1	HC24-1	Ø152-Ø610
VIT-224RA15	4	35	18.7	9075	28450	33.7	1520	240	11.02	MS200C	HJ24-1	HC24-1	Ø152-Ø610
VIT-232RA11	4	35	18.7	9585	25798	35.7	920	414	32.68	MS200C	HJ24-1	HC32-1	Ø100-Ø810
VIT-232RA15	4	35	18.7	9585	25798	35.7	920	399	32.4	MS200C	HJ24-1	HC32-1	Ø100-Ø810

UNIT : mm

DIM Model	A	B	C (H6)	D	E	F	G	H	J	K	M	N	O max.	O min.	P max.	P min.	Q	R	S	T	U	V	W	X	Y	Z	Z1	Reference
V-212RA6	304	125	220	30	25	106.375	171.45	133.35	18	6-M16	6	64	45.75	12.75	138	108	5.5	18	36	50	M20x2.5	6-M12	50	54.5	130	—	—	Fig2
V-212RA8	304	118	220	30	18	139.719	190	171.45	24	6-M16	6	64	45.75	12.75	145	115	5.5	18	36	50	M20x2.5	3-M8	50	54.5	130	—	—	Fig1
V-212RA11	304	150	220	30	50	196.869	171.45	235	28	6-M16	6	64	45.75	12.75	113	83	5.5	18	36	50	M20x2.5	6-M20	50	54.5	130	—	—	Fig3
V-215RA8	381	141	300	43	33	139.719	235	171.45	24	6-M20	6	78	49.75	24.25	71	36	5.5	25.5	55	62	M30x3.5	6-M16	60	66.5	165	—	—	Fig2
V-215RA11	381	130	300	43	22	196.869	260	235	32	6-M20	6	78	49.75	24.25	82	47	5.5	25.5	55	62	M30x3.5	3-M10	60	66.5	165	—	—	Fig1
V-215RA15	381	165	300	43	57	285.775	235	330.2	29	6-M20	6	78	49.75	24.25	47	12	5.5	25.5	55	62	M30x3.5	6-M24	60	66.5	165	—	—	Fig3
V-218RA8	450	141	300	43	33	139.719	235	171.45	24	6-M20	6	92	70.75	24.25	59	24	5.5	25.5	55	62	M30x3.5	6-M16	60	66.5	165	158	22	Fig2
V-218RA11	450	130	300	43	22	196.869	260	235	32	6-M20	6	92	70.75	24.25	70	35	5.5	25.5	55	62	M30x3.5	3-M10	60	66.5	165	158	22	Fig1
V-218RA15	450	165	300	43	57	285.775	235	330.2	29	6-M20	6	92	70.75	24.25	35	0	5.5	25.5	55	62	M30x3.5	6-M24	60	66.5	165	158	22	Fig3
V-221RA8	530	154	380	60	33	139.719	330.2	171.45	24	6-M24	6	87	93.5	27.5	64	29	9	25	55	64	M30x3.5	9-M16	60	77	180	155	22	Fig2
V-221RA11	530	148	380	60	27	196.869	330.2	235	30	6-M24	6	87	93.5	27.5	70	35	9	25	55	64	M30x3.5	6-M20	60	77	180	155	22	Fig2
V-221RA15	530	148	380	60	27	285.775	330.2	330.2	33	6-M24	6	87	93.5	27.5	70	35	9	25	55	64	M30x3.5	3-M12	60	77	180	155	22	Fig1
V-224RA8	610	154	380	60	33	139.719	330.2	171.45	24	6-M24	6	126.5	93.5	27.5	64	29	9	25	55	64	M30x3.5	9-M16	60	77	180	165.1	22	Fig2
V-224RA11	610	148	380	60	27	196.869	330.2	235	30	6-M24	6	126.5	93.5	27.5	70	35	9	25	55	64	M30x3.5	6-M20	60	77	180	165.1	22	Fig2
V-224RA15	610	148	380	60	27	285.775	330.2	330.2	33	6-M24	6	126.5	93.5	27.5	70	35	9	25	55	64	M30x3.5	3-M12	60	77	180	165.1	22	Fig1
V-232RA11	810	156	380	80	27	196.869	330.2	235	30	6-M24	6	104.8	196.5	25.5	47	12	5	25	55	74	M30x3.5	6-M20	60	93	210	165.1	22	Fig2
V-232RA15	810	156	380	80	27	285.775	330.2	330.2	33	6-M24	6	104.8	196.5	25.5	47	12	5	25	55	74	M30x3.5	3-M12	60	93	210	165.1	22	Fig1
V-232RA20	810	187	520	80	58	412.775	330.2	463.6	35	6-M24	6	104.8	196.5	25.5	16	-19	5	25	55	74	M30x3.5	6-M24	60	93	210	165.1	22	Fig3
VIT-212RA8	304	118	220	30	18	139.719	190	171.45	24	4-M16	6	64	45.75	12.75	145	115	5.5	18	36	50	M20x2.5	4-M8	50	54.5	130	—	—	Fig1
VIT-218RA11	450	130	300	43	22	196.869	260	235	32	4-M20	6	92	70.75	24.25	70	35	5.5	25.5	55	62	M30x3.5	4-M10	60	66.5	165	158	22	Fig1
VIT-224RA11	610	162	380	60	41	196.869	330.2	235	30	8-M24	6	126.5	93.5	27.5	70	35	9	25	56	64	M30x3.5	6-M20	60	77	180	165.1	22	Fig2
VIT-224RA15	610	148	380	60	27	285.775	330.2	330.2	33	8-M24	6	126.5	93.5	27.5	70	35	9	25	55	64	M30x3.5	4-M12	60	77	180	165.1	22	Fig1
VIT-232RA11	810	170	380	80	41	196.869	330.2	235	30	8-M24	6	104.8	196.5	25.5	47	12	5	25	56	74	M30x3.5	6-M20	60	93	210	200	22	Fig2
VIT-232RA15	810	156	380	80	27	285.775	330.2	330.2	33	8-M24	6	104.8	196.5	25.5	47	12	5	25	55	74	M30x3.5	4-M12	60	93	210	200	22	Fig1

CR

Collet chuck for cylindrical center mount

1. Collet chucks with bayonet catch are mainly used for chucking bar work on NC / CNC lathes.
2. The bar can be fed in through the chuck.
3. Profiles can also be chucked with the appropriate collets.

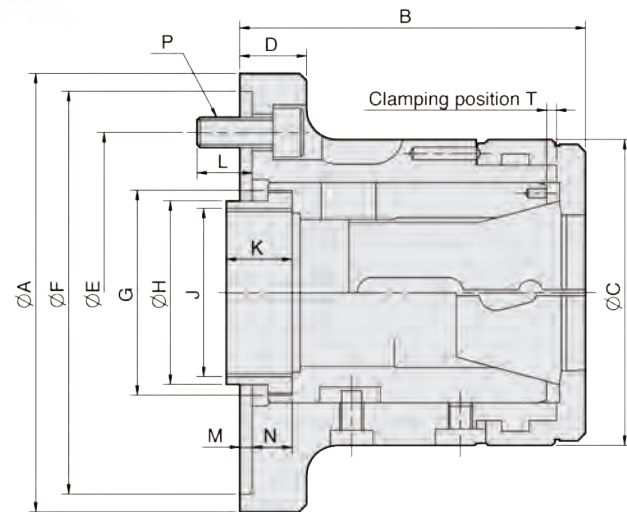

UNIT : mm

SPEC Model	Matching Adapter	Bar Capacity (mm)	Sleeve Stroke (mm)	Max. Push Force kN(kgf)	Max. Gripping Force kN(kgf)	Max. Speed (r.p.m.)	Weight (kg)
CR42-140	140	42	7	25(2549)	55(5608)	6000	6.2
CR60-170	170	60	7	30(3059)	65(6628)	5000	11.5
CR60-220	220	60	7	30(3059)	65(6628)	5000	15.5

DIM Model	A (h6)	B	C	D	E	F (H6)	G	H	J max.	K	L	M	N	P	T
CR42-140	155	114	100	23	104.78	140	M66xP1.5	60	M55xP2.0	25	18	6	11.9	3-M10	3.1
CR60-170	185	139	130	30	133.35	170	M90xP1.5	80	M74xP2.0	30	18	6	17.9	6-M12	3.1
CR60-220	235	141	130	32	171.45	220	M90xP1.5	80	M74xP2.0	30	20	6	19.9	6-M16	3.1

Collet Drawings

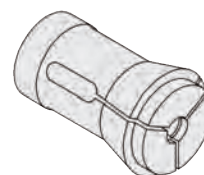

- Spring Collet -

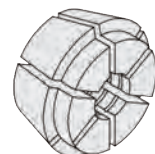

- Multi-Bore Collet -

Capacities Chuck	MULTIBORE	SPRING COLLET
NO.	Cat.No. / ○ / ○ / □	Cat.No. / ○ / ○ / □
CR42	M-673 / 42 / 36 / 30	173E/4728 / 42 / 36 / 30
CR60	M-677 / 60 / 52 / 42	185E/4291 / 60 / 52 / 42

*Uses the collet to DIN6343 specification.

CRA

Collet chuck for short taper mount

1. Collet chucks with bayonet catch are mainly used for chucking bar work on NC / CNC lathes.
2. The bar can be fed in through the chuck.
3. Profiles can also be chucked with the appropriate collets.

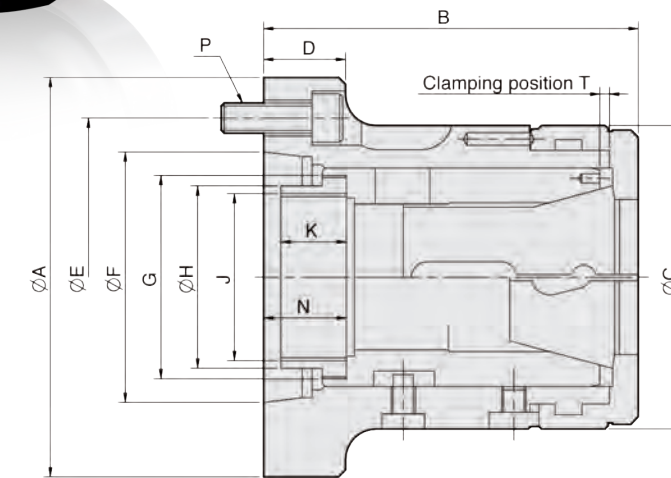

UNIT : mm

SPEC Model	Matching Spindle	Bar Capacity (mm)	Sleeve Stroke (mm)	Max. Push Force kN(kgf)	Max. Gripping Force kN(kgf)	Max. Speed (r.p.m.)	Weight (kg)
CR26A4	A2-4	26	5	20(2039)	44(4486)	7000	4.5
CR30A4	A2-4	30	5	20(2039)	44(4486)	7000	4.1
CR42A5	A2-5	42	7	25(2549)	55(5608)	6000	6.2
CR42A6	A2-6	42	7	25(2549)	55(5608)	6000	8.2
CR60A6	A2-6	60	7	30(3059)	65(6628)	5000	13
CR80A8	A2-8	80	7	35(3568)	73(7443)	4000	21

DIM Model	A	B	C	D	E	F	G	H	J max.	K	N	P	T
CR26A4	112	103.5	85	30	82.55	63.513	M50xP1.5	45	M40xP1.5	15	21.7	3-M10	2.3
CR30A4	112	103.5	85	30	82.55	63.513	M50xP1.5	45	M40xP1.5	15	21.7	3-M10	2.3
CR42A5	135	124	100	27	104.78	82.563	M66xP1.5	60	M55xP2.0	25	27.4	4-M10	3.1
CR42A6	170	124	100	32	133.35	106.375	M66xP1.5	66	M60xP2.0	22	27.4	4-M12	3.1
CR60A6	170	145	130	27	133.35	106.375	M90xP1.5	80	M74xP2.0	30	29.9	4-M12	3.1
CR80A8	220	170	156	35	171.45	139.719	M114xP2.0	99	M90xP2.0	27.5	32.4	6-M16	6.1

Capacities Chuck	MULTIBORE	SPRING COLLET
NO.	Cat.No. / ○ / ○ / □	Cat.No. / ○ / ○ / □
CR26	M-667 / 26 / 22 / 18	161E/8744 / 26 / 22 / 18
CR30	M-669 / 30 / 26 / 21	163E/4249 / 30 / 26 / 21
CR42	M-673 / 42 / 36 / 30	173E/4728 / 42 / 36 / 30
CR60	M-677 / 60 / 52 / 42	185E/4291 / 60 / 52 / 42
CR80	J-660 / 80 / 69 / 56	193E/H-47 / 80 / 69 / 56

*Uses the collet to DIN6343 specification.

Collet Drawings

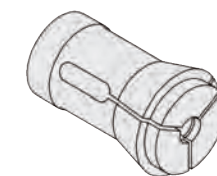

- Spring Collet -

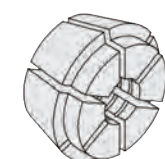

- Multi-Bore Collet -



MK

Super high speed through-hole compact rotary hydraulic cylinder

1. The compact hydraulic cylinder which is shorten the length about 30% and light weight can reduce the spindle loading while running in high speed.
2. Built-in check valve in safety auto lock and pressure relief valve in case of power failure occurs.
3. New model developed for rear locking installation.

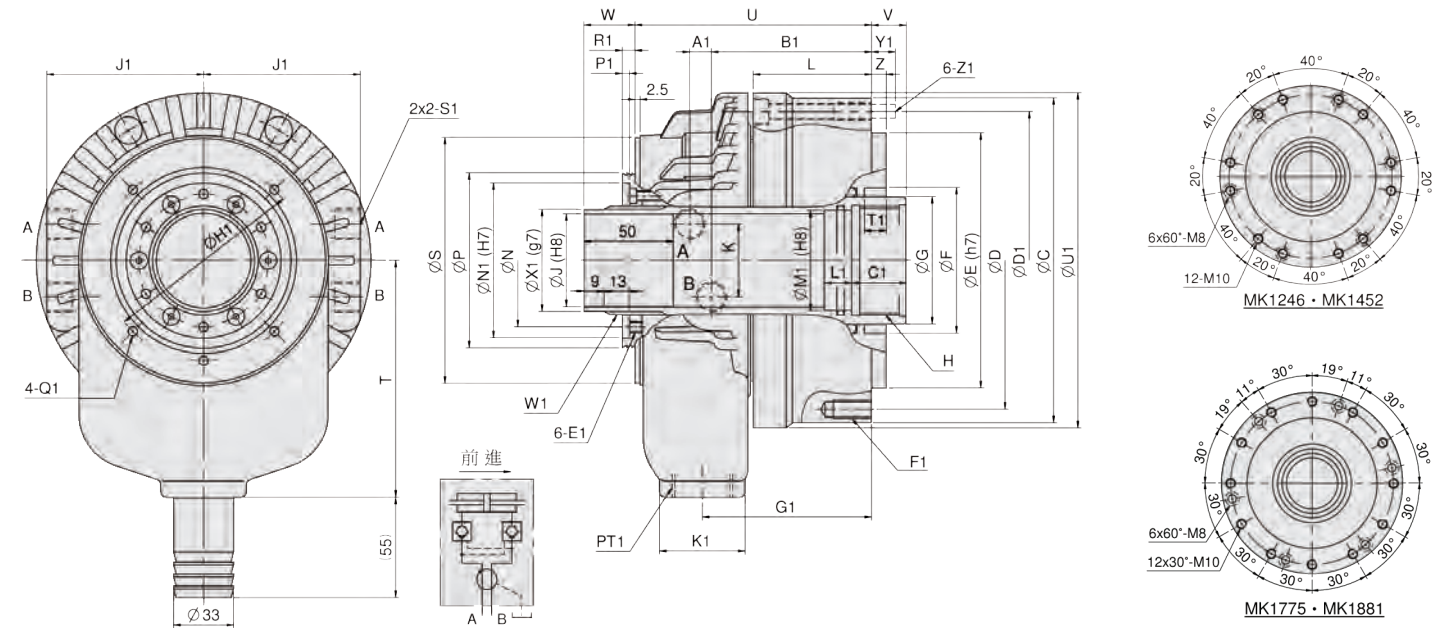

UNIT : mm

DIM Model	A1	B1	C1	E1	F1	G1	H1	J1	K1	L1	M1	N1	P1	Q1	R1	S1	T1	U1	W1	X1	Y1	Z1
MK1246	8.5	79.5	25	M6x10	12-M10x20	84	98	76	47	15	50	76	4	M5x6	9	PT 3/8	12	165	M52x1.5	50	15	M8
MK1246F	8.5	89.5	30	M6x10	6-M10x20	94	98	76	47	15	50	76	4	M5x6	9	PT 3/8	8	165	M52x1.5	50	15	M8
MK1452	9	88	30	M6x12	12-M10x20	93	110	86	47	15	55	85	4	M6x6	16	PT 3/8	12	184	M58x1.5	56	12	M8
MK1452F	9	95	30	M6x12	6-M10x20	100	110	86	47	15	55	85	4	M6x6	16	PT 3/8	8	184	M58x1.5	56	15	M8
MK1768	17.5	99	30	M6x12	12-M10x20	110	155	100	47	15	70	108	4	M6x10	7	PT 1/2	12	216	M84x2.0	81	18	M10
MK1775	17.5	99	30	M6x12	12-M10x20	110	155	100	47	15	80	108	4	M6x10	7	PT 1/2	12	216	M84x2.0	81	18	M10
MK1778	17.5	99	30	M6x12	12-M10x20	110	155	100	47	15	82	108	4	M6x10	7	PT 1/2	12	216	M84x2.0	81	18	M10
MK1881	17	106	35	M6x12	12-M10x20	115	166	105	47	15	85	113	4	M6x10	16.5	PT 1/2	12	226	M89x2.0	86	19	M10

UNIT : mm

SPEC Model	Piston Dia. (mm)	Piston Area (cm²) Push Side / Pull Side	Max. Draw Bar Force kN(kgf) Push Side / Pull Side	Piston Stroke (mm)	Max. Operating Pressure MPa(kgf / cm²)	Max. Speed (r.p.m.)	Moment Of Inertia I (kg · m²)	Weight (kg)	Total Leakage L/min
MK1246	128	102.6 / 91.4	43.6(4466) / 38.9(3967)	16	4.5(45.9)	8000	0.017	8.6	3.1
MK1246F	128	102.6 / 91.4	43.6(4466) / 38.9(3967)	16	4.5(45.9)	8000	0.018	9.2	3.1
MK1452	145	133 / 122.6	56.5(5761) / 52.1(5313)	22	4.5(45.9)	6500	0.028	12	3.9
MK1452F	145	133 / 122.6	56.5(5761) / 52.1(5313)	22	4.5(45.9)	6500	0.029	12.5	3.9
MK1768	170	166 / 152	70.7(7209) / 64.7(6597)	25	4.5(45.9)	5500	0.065	19.4	4.5
MK1775	170	166 / 152	70.7(7209) / 64.7(6597)	25	4.5(45.9)	5500	0.060	17.8	4.5
MK1778	170	166 / 152	70.7(7209) / 64.7(6597)	25	4.5(45.9)	5500	0.059	17.4	4.5
MK1881	180	187 / 171.9	79.5(8107) / 73.1(7454)	25	4.5(45.9)	4800	0.087	24	4.5

DIM Model	C	D	D1	E	F	G	H	J	K	L	N	P	S	T	U	V max.	V min.	W max.	W min.	Z
MK1246	162	147	147	130	75	65	M55x2.0	46	40	58	64	85	116	120	120	13	-3	44	28	8
MK1246F	162	130	147	100	75	65	M55x2.0	46	40	68	64	85	116	120	130	14	-2	44	28	5
MK1452	184	165	165	140	80	70	M60x2.0	52	40	66	73	96	135	130	130	19	-3	53.5	31.5	8
MK1452F	186	170	165	130	80	70	M60x2.0	52	40	73	73	96	135	130	137	21	-1	53.5	31.5	5
MK1768	212	195	195	160	105	95	M75x2.0	68	46	71	98	121	164	160	157	22	-3	50	25	8
MK1775	212	195	195	160	105	95	M85x2.0	75	46	71	98	121	164	160	157	22	-3	50	25	8
MK1778	212	195	195	160	105	95	M87x2.0	78	46	71	98	121	164	160	157	22	-3	50	25	8
MK1881	222	205	205	168	110	100	M90x2.0	81	46	71	103	126	175	175	167	23	-2	58	33	8



CM.B

Hydraulic cylinder coolant collector

1. Hydraulic cylinders coolant collectors. Compact and light weight, they feature bore sizes up to 20% large than Conventional Cylinders. Precision finished piston bores and cool running rotary unions are included for years of trouble-free performance.
2. The proximity switches are extra option.



ML-CM.B

Extra large through-hole rotary hydraulic cylinder

1. Matching for large bore power chucks.
2. Special aluminum alloy steel body, light weight for reducing the spindle loading.
3. Within check valves to maintain the thrust force.
4. Extra large bore design, equipped with coolant collector and detective plate.
5. The proximity switches and mounting bolts are extra option.

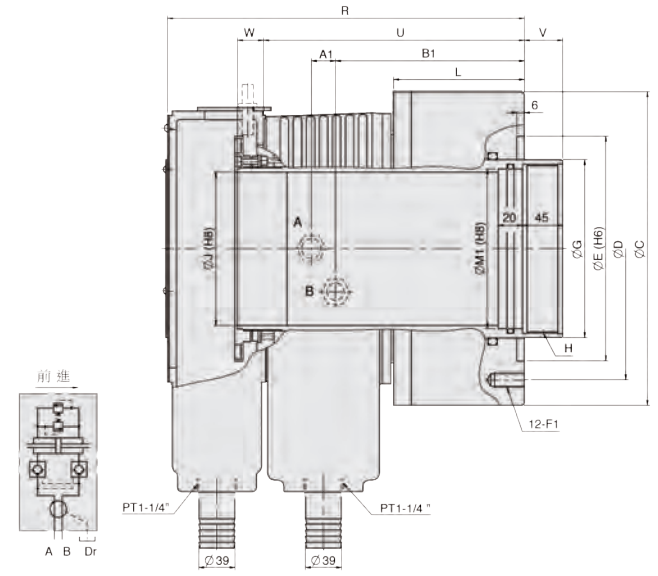
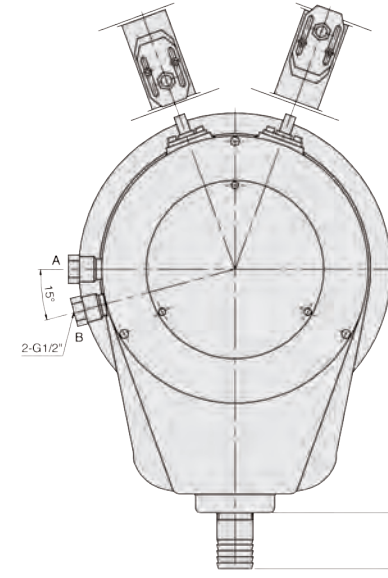
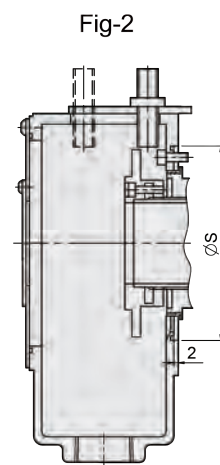
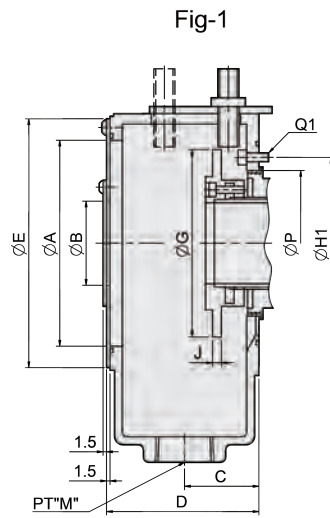
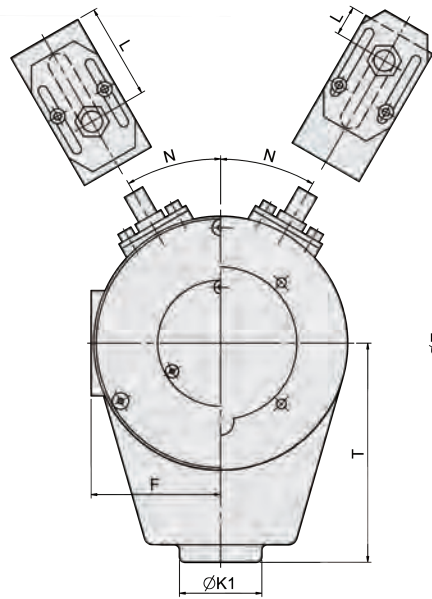

UNIT : mm

DIM Model	A	B	C	D	E	F	G	J	L max.	L min.	N	P	S	T	M	H1	K1	Q1	Reference	Matching Cylinder	Weight (kg)
CM09B	82.5	30	35	71.5	106	55.5	77	5	47.5	17.5	30	67	90	105	PT 3/4"	76	44	4-M4	Fig2	M0928	0.85
CM10B1	82.5	40	35	71.5	106	55.5	107	5	47.5	17.5	30	75	-	105	PT 3/4"	88	44	6-M5	Fig1	M1036	1.0
CM12B	117.5	48	42	85.5	142	74	107	5	60.5	17.5	30	87	-	130	PT 1"	98	47	4-M5	Fig1	M1236, M1246, MK1246, MM1246A	1.6
CM15B8	117.5	55	42	85.5	142	74	107	5	60.5	17.5	30	98	-	130	PT 1"	110	47	4-M6	Fig1	M1546, M1552, MK1452	1.6
CM18B	155	80	42.5	86.5	184	94	147	5	58.5	17.5	30	123	-	150	PT 1"	155	47	4-M6	Fig1	M1868, M1875	2.0
CM18BK	155	80	42.5	86.5	184	94	147	5	60.5	19.5	30	126	175	150	PT 1"	166	47	4-M6	Fig2	MK1881	2.0
CM20B	155	95	42.5	86.5	184	94	147	5	60.5	17.5	30	140	-	150	PT 1"	165	47	4-M6	Fig1	M2091	2.1
CM25B	200	120	44	89.5	230	117	192	12	60	21	27	179	-	180	PT 1"	206	47	4-M6	Fig1	M2511	2.4
CM28B	254	170	52	103	285	147	240	8	74.5	20.5	20	222.6	278	260	PT 1-1/4"	256	85	4-M6	Fig2	ML2816	4.2
CM33B	300	208	52	101.5	330	-	285	8	74.5	20.5	20	262.6	328	259	PT 1-1/4"	308	70	4-M6	Fig2	ML3320	7.2

UNIT : mm

SPEC Model	Piston Dia. (mm)	Piston Area (cm ²) Push Side / Pull Side	Max. Draw Bar Force (kN(kgf)) Push Side / Pull Side	Piston Stroke (mm)	Max. Operating Pressure (MPa(kgf/cm ²))	Max. Speed (r.p.m.)	Moment Of Inertia I (kg · m ²)	Weight (kg)	Total Leakage (L/min)
ML2814CM28B	285	394 / 350	116.8(11910) / 106.8(10584)	42	3.3(33.6)	2000	1.08	87	9
ML2816CM28B	285	394 / 350	116.8(11910) / 106.8(10584)	42	3.3(33.6)	2000	0.90	72	9
ML3320CM33B	335	515.7 / 416.9	152.9(15591) / 136.9(13960)	42	3.3(33.6)	1600	1.09	103	10

DIM Model	C	D	E (H6)	G	H	J	L	R	T	U	V max.	V min.	W max.	W min.	A1	B1	F1	M1
ML2814CM28B	335	280	240	190	M158x3.0	145	140	382	260	279	41	-1	67	25	18	202	M16x32L	150
ML2816CM28B	335	280	240	190	M180x3.0	166.5	140	382	260	279	41	-1	67	25	18	202	M16x32L	170
ML3320CM33B	390	320	280	230	M215x3.0	205	147	392	260	292	41	-1	67	25	18	210	M20x32L	210

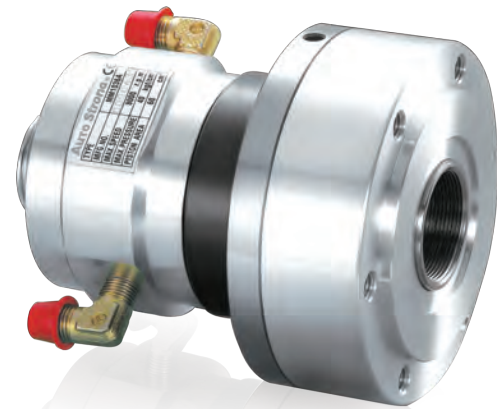

MM

High speed and compact through-hole rotary hydraulic cylinder

1. Compact hydraulic cylinder design with light weight can reduce the spindle loading while running in high speed.
2. Built-in check valve in safety auto lock and pressure relief valve in case of power failure occur.
3. New model developed for rear installation.



MS

Non through-hole rotary hydraulic cylinder (valve included)

- Built-in safety check valves.

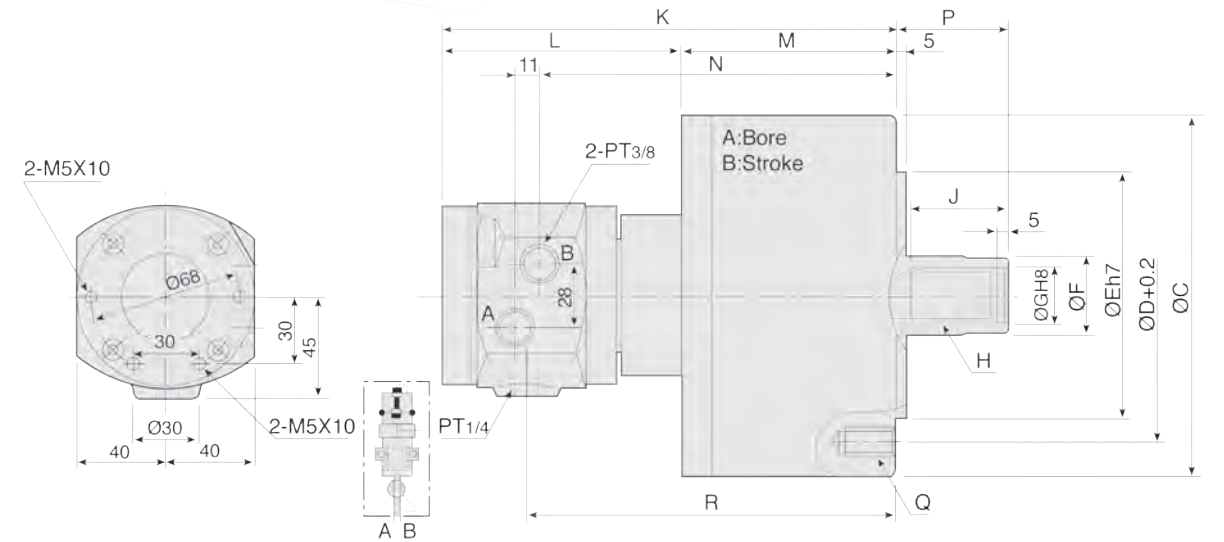
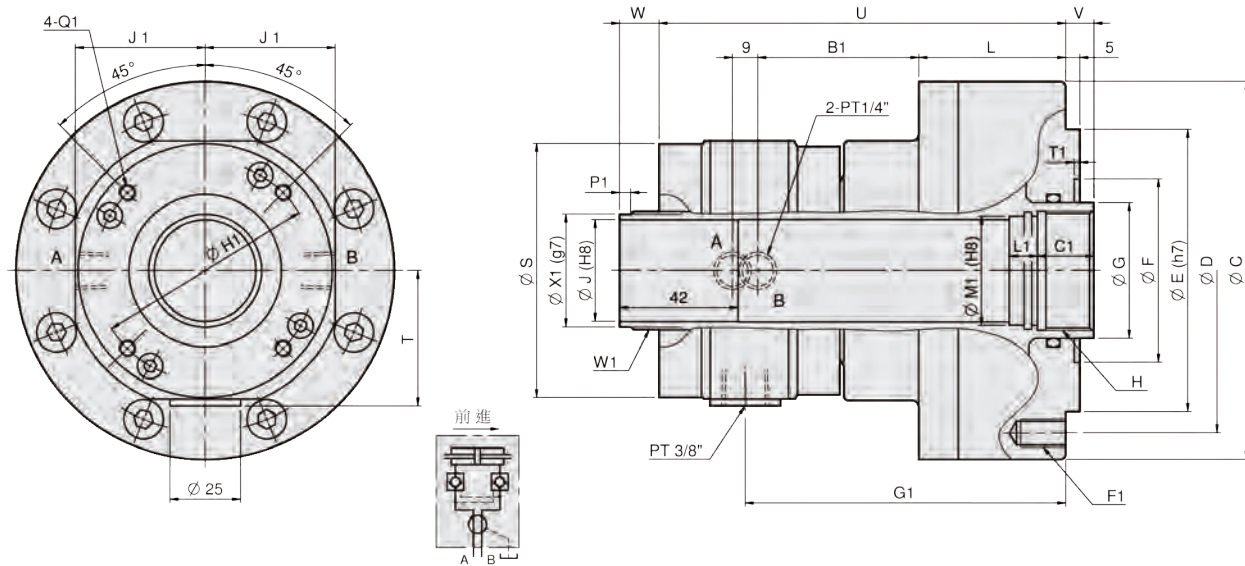

UNIT : mm

SPEC Model	Piston Dia. (mm)	Piston Area (cm²) Push Side / Pull Side	Max. Draw Bar Force (kN/kgf) Push Side / Pull Side	Piston Stroke (mm)	Max. Operating Pressure (MPa(kgf / cm²))	Max. Speed (r.p.m.)	Moment Of Inertia I (kg · m²)	Weight (kg)	Total Leakage (L/min)
MM1036A	36	64 / 60	23.8(2427) / 22.3(2274)	5	4.0(40.8)	8000	0.013	7	0.8
MM1246A	46	100 / 89	38(3875) / 33(3365)	15	4.0(40.8)	7000	0.026	9.8	3.0

DIM Model	C	D	E	F	G	H	J	L	T	U	V	V	W	W	B1	C1	F1	G1	H1	J1	L1	M1	Q1	T1	W1	P1	X1
										max.	min.	max.	min.														
MM1036A	134	115	100	65	48	M42x1.5	36	52	48	144	10	5	17	12	57	20	6-M10x15	113.5	76	46	10	38	M4x9L	2	M42xP1.5	2	40
MM1246A	155	130	100	80	65	M55x2.0	46	76	61	179	15	0	40	25	59.5	30	12-M10x20	140	98	59	15	50	M5x10L	6	M52xP1.5	9	50

UNIT : mm

SPEC Model	Piston Area (cm²) Push Side / Pull Side	Max. Draw Bar Force (kN/kgf) Pull Side	Piston Stroke (mm)	Max. Operating Pressure (MPa(kgf / cm²))	Max. Speed (r.p.m.)	Moment Of Inertia I (kg · m²)	Weight (kg)	Total Leakage (L/min)
MS105	86 / 79	29(2957)	20	4.0(40.8)	6000	0.0125	7.1	0.8
MS125	122 / 113	42(4283)	25	4.0(40.8)	6000	0.0225	10	0.8
MS150	176 / 160	60(6118)	30	4.0(40.8)	5500	0.0475	13.5	0.8
MS200	314 / 290	108(11013)	35	4.0(40.8)	5500	0.0975	22	0.8

DIM Model	A	B	C	D	E	F	G	H	J	K	L	M	N	P	P	Q	R
														max.	min.		
MS105	105	20	135	100	80	30	21	M20x2.5	35	197	108	89	152	45	25	6-M10x20	158
MS125	125	25	160	130	110	35	25	M24x3.0	44	205	108	97	160	51	26	6-M12x24	166
MS150	150	30	190	130	110	45	31	M30x3.5	45	214	108	106	169	56	26	12-M12x24	175
MS200	200	35	245	145	120	55	37	M36x4.0	60	228	108	122	183	69	34	12-M16x30	189

MS-C

Non through-hole rotary hydraulic cylinder (valve and switch brackets included)

1. Built-in safety check valves and detective plate.
2. The proximity switches are extra option.

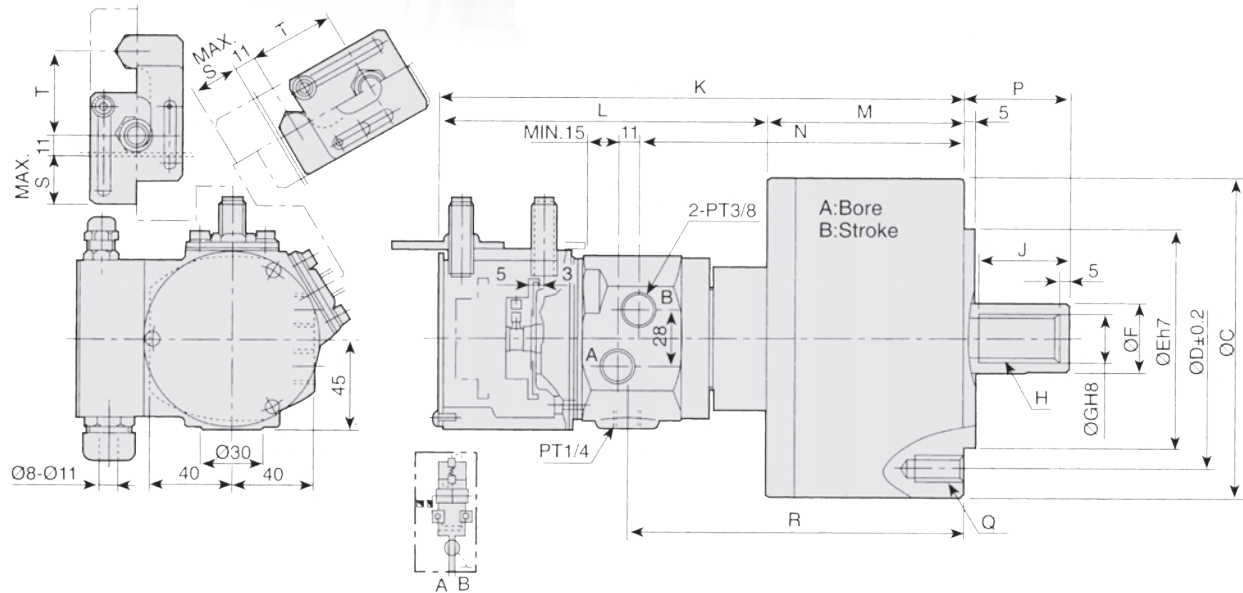

UNIT : mm

SPEC Model	Piston Area (cm²) Push Side / Pull Side	Max. Draw Bar Force (kN/kgf) Push Side / Pull Side	Piston Stroke (mm)	Max. Operating Pressure (MPa/kgf / cm²)	Max. Speed (r.p.m.)	Moment Of Inertia I (kg · m²)	Weight (kg)	Total Leakage (L/min)
MS105C	84 / 79	29 (2957)	20	4.0(40.8)	6000	0.0125	7.6	0.8
MS125C	120 / 113	42 (4283)	25	4.0(40.8)	6000	0.022	10.5	0.8
MS125C35	120 / 113	42 (4283)	35	4.0(40.8)	6000	0.022	10.5	0.8
MS150C	174 / 160	60 (6118)	30	4.0(40.8)	5500	0.047	14	0.8
MS200C	312 / 290	108 (11013)	35	4.0(40.8)	5500	0.097	22.5	0.8

DIM Model	A	B	C	D	E	F	G	H	J	K	L	M	N	P max.	P min.	Q	R	S	T
MS105C	105	20	135	100	80	30	21	M20x2.5	35	257	168	89	152	45	25	6-M10x20	158	23	46
MS125C	125	25	160	130	110	35	25	M24x3.0	44	265	168	97	160	51	26	6-M12x24	166	23	46
MS125C35	125	35	160	130	110	35	25	M24x3.0	44	269	168	101	164	57	22	6-M12x24	170	23	46
MS150C	150	30	190	130	110	45	31	M30x3.5	45	274	168	106	169	56	26	12-M12x24	175	23	46
MS200C	200	35	245	145	120	55	37	M36x4.0	60	288	166	122	183	69	34	12-M16x30	189	28	46

· Draw bar pull force : Pressure 4.0 MPa(40.8kgf / cm²)
 · Total leakage : Pressure 3.0 MPa(30.6kgf / cm²) and oil temperature 50°C
 · Proximity switch : Model BESS 16-329-E4-Y (BALLUFF) DC 12 / 24V 200mA NPN

MS250C/MS300C

Non through-hole rotary hydraulic cylinder (valve and switch brackets included)

1. Through-hole for coolant, oil or air with thread for rotary unit.
2. Mounting from the rear or front side.
3. Built-in safety check valves and bracket for proximity switch. (The proximity switches are extra option.)

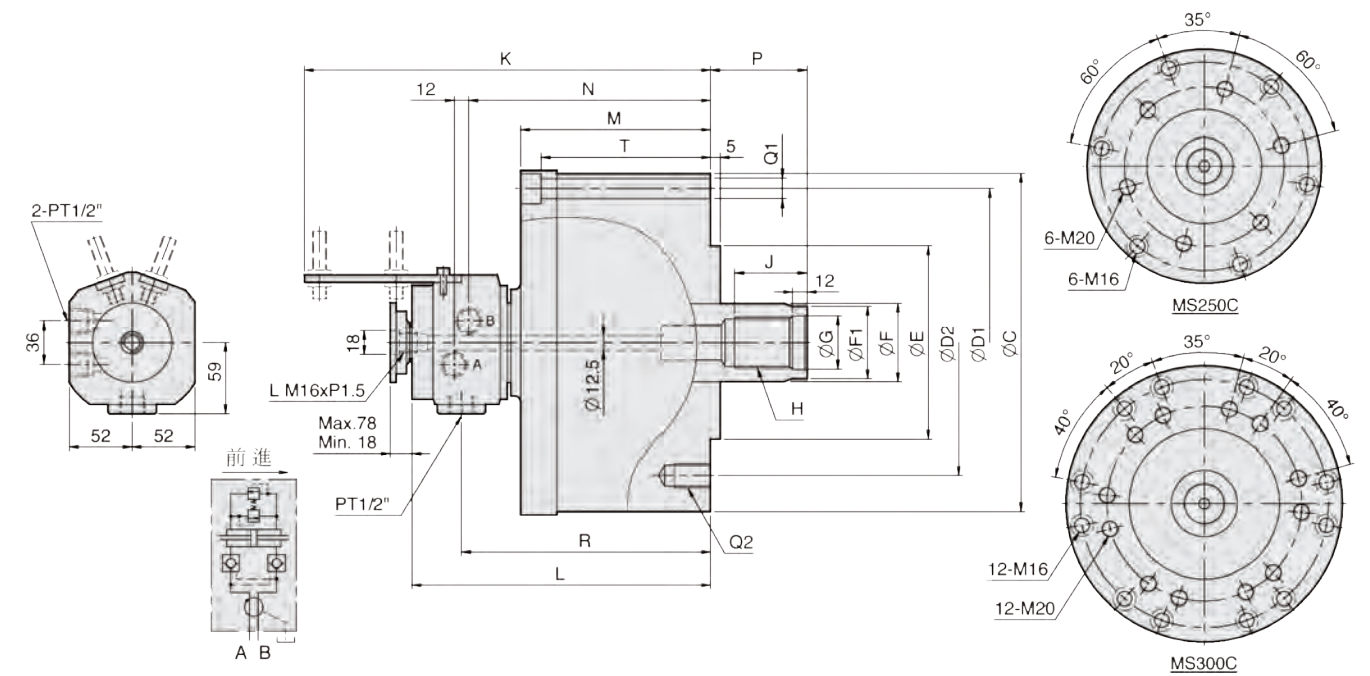

UNIT : mm

SPEC Model	Piston Dia. (mm)	Piston Area (cm²) Push Side / Pull Side	Max. Draw Bar Force (kN/kgf) Push Side / Pull Side	Piston Stroke (mm)	Max. Operating Pressure (MPa/kgf / cm²)	Max. Speed (r.p.m.)	Moment Of Inertia I (kg · m²)	Weight (kg)	Total Leakage (L/min)
MS250C	250	481.5 / 453.6	227(23147) / 214(21822)	60	4.9(50)	2000	0.87	78	2
MS300C	300	697.5 / 658.6	262(26716) / 247(25186)	60	4.0(40.8)	1500	1.6	106	3

DIM Model	C	D1	D2	E (h7)	F	F1	G	H	J	K	L	M	N	P max.	P min.	Q1	Q2	R	T
MS250C	300	275	220	160	65	62	44	M42x3.0	60	356	267	177	220	85	25	6-Ø17	6-M20x30	226	160
MS300C	355	330	270	210	75	70	50	M48x3.0	70	359	270	182	223	85	25	12-Ø17	12-M20x30	229	165



MR

Short Type Non Through Hole Rotary Hydraulic

1. Light weight design can reduce the spindle loading for vertical lathe application.
2. Built-in check valve and proximity switch brackets.
3. Developed for rear locking installation.

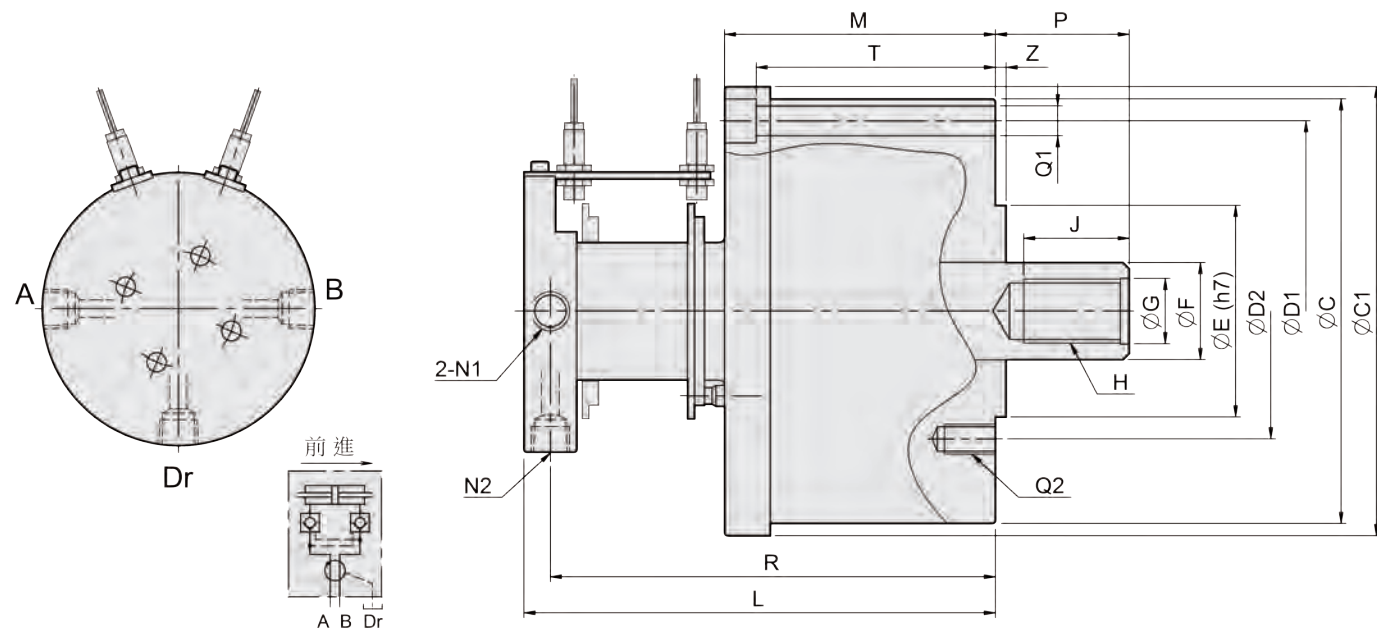

UNIT : mm

SPEC Model	Piston Dia. (mm)	Piston Area (cm ²) Push Side / Pull Side	Max. Draw Bar Force (kN/kgf) Push Side / Pull Side	Piston Stroke (mm)	Max. Operating Pressure (MPa/kgf / cm ²)	Max. Speed (r.p.m.)	Moment Of Inertia I (kg · m ²)	Weight (kg)	Total Leakage (L/min)
MR15035	150	171.1 / 156.7	72(7342) / 66(6730)	35	4.5(45.9)	5500	0.043	12.8	0.8
MR20060	200	310 / 286	146(14887) / 134(13664)	60	4.9(50)	5500	0.55	49	2
MR25060	250	481.5 / 453.6	227(23147) / 214(21822)	60	4.9(50)	2000	0.81	72	2

DIM Model	C	C1	D1	D2	E (h7)	F	G	H	J	L	M	N1	N2	P max.	P min.	Q1	Q2	R	T	Z
MR15035	202	204	180	130	110	45	31	M30x3.5	45	175	95	PT 3/8"	PT 1/4"	61	26	6-Ø13	12-M12	163	82	5
MR20060	250	255	225	145	120	55	37	M36x4.0	60	270	156	PT 1/2"	PT 1/2"	85	25	6-Ø17	6-M16	255	140	6
MR25060	300	305	275	220	160	65	44	M42x3.0	60	280	168	PT 1/2"	PT 1/2"	85	25	6-Ø17	6-M20	265	150	6



MH

Non through-hole rotary hydraulic cylinder

1. Compact, low inertia, light weight cylinder :
Manufactured by aluminium alloy, this cylinder is light weight design to reduce the loading of spindle.
2. High speed :
This balanced design cylinder is light weight, compact and maintains outstanding stability during high speed operation.
3. Long life :
High quality cylinder seals and high accuracy surface finish on components to ensure the long life of these cylinders.

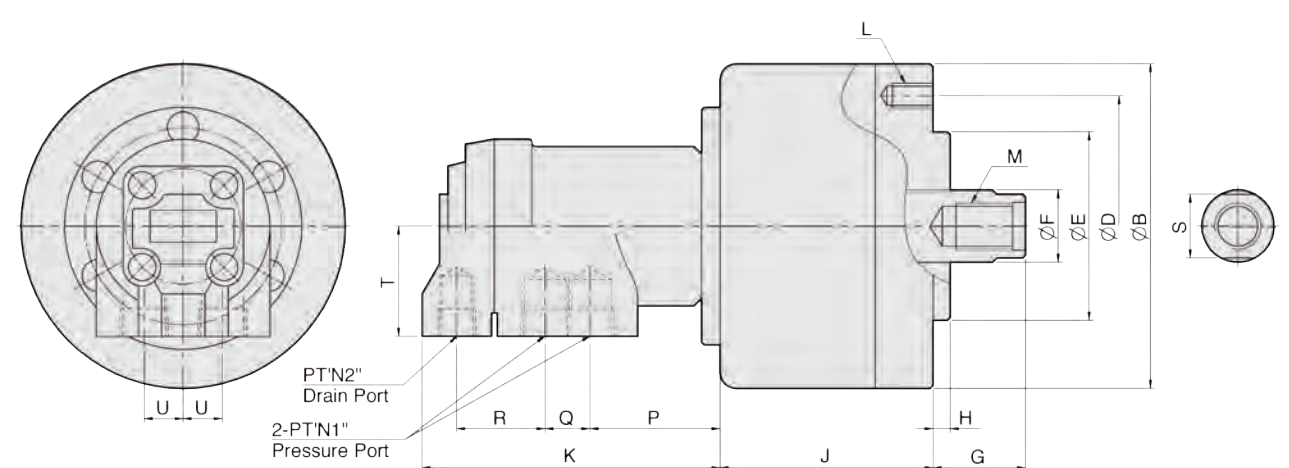

UNIT : mm

SPEC Model	Piston Dia. (mm)	Piston Area (cm ²) Push Side / Pull Side	Max. Draw Bar Force (kN/kgf) Push Side / Pull Side	Piston Stroke (mm)	Max. Operating Pressure (MPa/kgf / cm ²)	Max. Speed (r.p.m.)	Moment Of Inertia I (kg · m ²)	Weight (kg)	Total Leakage (L/min)
MH80	80	47.7 / 42.8	15.5(1580) / 13.9(1417)	15	3.5(35.7)	6000	0.005	5.1	0.4
MH100	100	75.4 / 70.5	24.5(2498) / 22.9(2335)	20	3.5(35.7)	5500	0.0125	6.6	0.4
MH125	125	121.1 / 114	39.3(4007) / 37(3773)	25	3.5(35.7)	5500	0.02	8.4	0.4
MH150	150	176 / 160	66(6730) / 60(6118)	30	4.0(40.8)	4000	0.047	10.4	0.8

DIM Model	B	D	E (h7)	F	G max.	G min.	H	J	K	L	M	N1	N2	P	Q	R	T	U	S
MH80	112	90	65	25	45	30	6	73.5	103	6-M8x16	M16x2.0x32	3/8"	1/4"	45	15.5	30.5	38	13.5	22
MH100	135	100	80	25	45	25	6	88.5	103	6-M10x19	M16x2.0x32	3/8"	1/4"	45	15.5	30.5	38	13.5	22
MH125	160	130	110	30	51	26	6	95.5	103	6-M12x20	M20x2.5x32	3/8"	1/4"	45	15.5	30.5	38	13.5	27
MH150	190	130	110	45	50	20	6	107	103	12-M12x20	M30x3.5x40	3/8"	1/4"	45	15.5	30.5	38	13.5	38



HB4

Boring mill jaw

1. Clamping of workpiece for larger size lathe, vertical lathe, die set with jig.
2. One set of 4-piece with T-bolt.

UNIT : mm

SPEC Model	Jaw Stroke (mm)	Max. Gripping Force (kN)	Weight (kg)
HB4-160	50	39.2	29

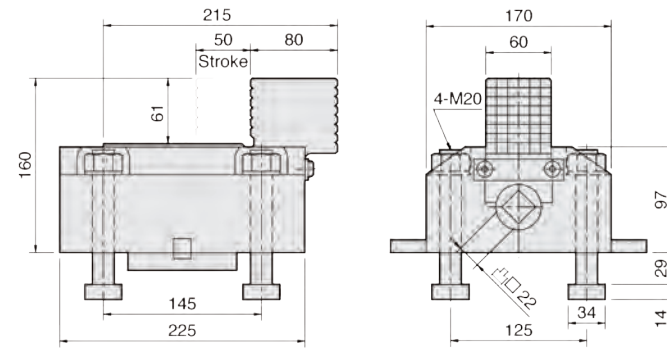

UNIT : mm

SPEC Model	Jaw Stroke (mm)	Max. Gripping Force (kN)	Weight (kg)
HB4-189	50	39.2	31

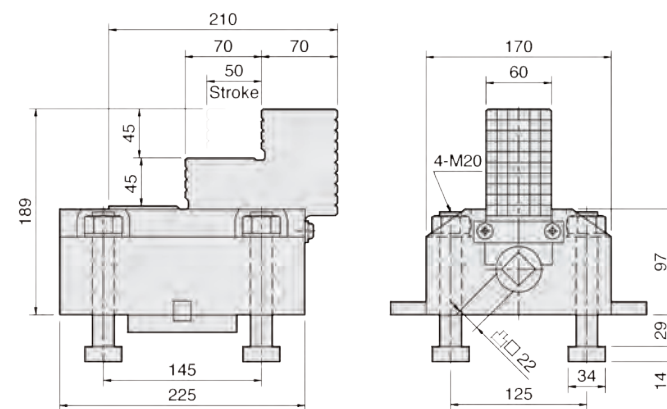

UNIT : mm

SPEC Model	Jaw Stroke (mm)	Max. Gripping Force (kN)	Weight (kg)	Matching Soft Jaw
HB4-2P	50	39.2	31	HE2486

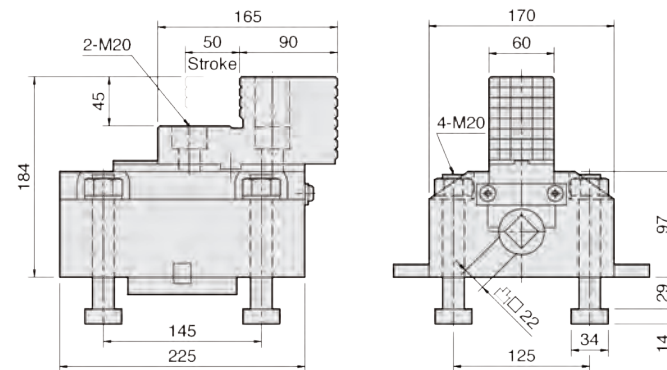

SKC

Soft jaw for strong scroll chuck

1. Soft jaws for strong scroll chuck.
2. Manufactured in special specification.

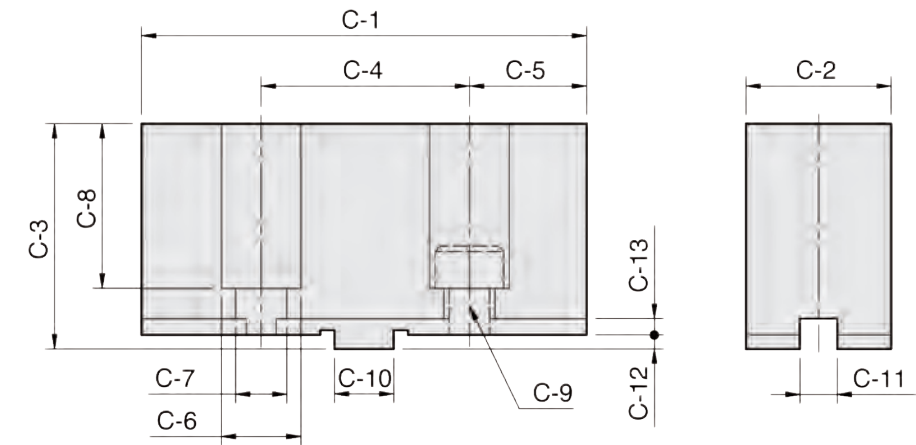

UNIT : mm

SPEC Model	C-1	C-2	C-3	C-4	C-5	C-6	C-7	C-8	C-9	C-10	C-11	C-12	C-13	Matching Chuck	3 Jaw Weight (kg)
SKC04	52	19	30	24	14	11	7	21	M6	9.53	7.94	2.5	3	SK-4	0.45
SKC06	73	26	37	38	17.5	14	8.5	27	M8	12.68	7.94	3	3.5	SK-6, KD-6"	1.5
SKC07	95	31	48	44.5	25.25	17	11	35	M10	12.68	7.94	3	3.5	SK-7, SK-8, KD-8", KA-8"	2.7
SKC09	110	37	48	54	28	19	13	34	M12	19.03	12.7	3	3.5	SK-9, SK-10, KD-10", KA-10"	3.7
SKC12	125	40	54	63.5	30.75	19	13	40.5	M12	19.03	12.7	3	3.5	SK-12, KD-12", KA-12"	4.9
SKC16	160	50	70	76.2	41.9	25	17	48	M16	19.03	12.7	6	3.5	SK-16	11
HE2486	155	59	86	76.2	52.9	32	22	66	M20	19.03	12.7	6	4	HB4-2P	19.2(4PC)



HC

Soft jaw for hydraulic power chuck

1. Soft jaws for hydraulic power chucks.
2. Soft jaw for CNC lathe.

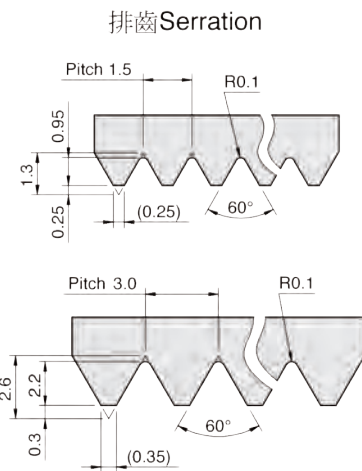
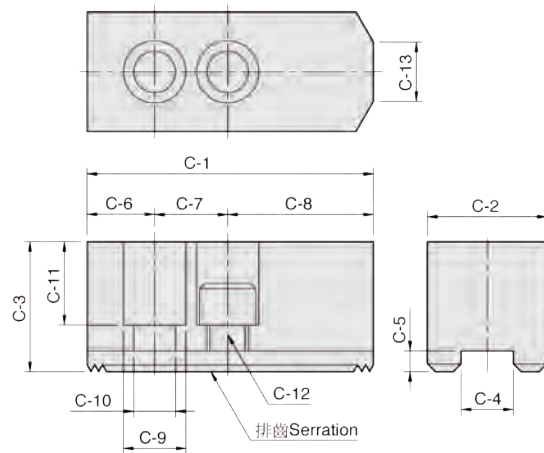

DIM Model	C-1	C-2	C-3	C-4	C-5	C-6	C-7	C-8	C-9	C-10	C-11	C-12	C-13	Serration Pitch	Matching Chuck	3 Jaw Weight (kg)
HC04	53	23	23	10	5	9	14	30	14	9	14	M8	3	1.5x60°	N-204	0.45
HC05	62	25	30	10	5	9	14	39	14	9	21	M8	5	1.5x60°	N-205	0.7
HC06	73	31	36	12	5	15	20	38	17	11	21	M10	14	1.5x60°	N-206, NB-306, V-206	1.5
HC08	95	35	37	14	5	24	25	46	19	13	22	M12	16	1.5x60°	N-208, NB-208, V-208	2.4
HC10	110	40	42	16	5	30	30	50	19	13	27	M12	18	1.5x60°	N-210, NB-210, V-210	3.7
HC12	130	50	50	21	5	39	30	61	25	17	33	M16	23	1.5x60°	N-212, NB-212	6.5
HC15	165	62	62	22	8	37	43	85	32	21	38	M20	—	1.5x60°	N-215, N-218, NB-215, NB-218	12.5
HC08-1	95	35	37	12	5	24	20	51	17	11	21	M10	14	1.5x60°	NHT-208	2.4
HC12-1	130	50	50	18	5	39	30	61	23	15	30	M14	23	1.5x60°	V-212, V-212R	6.6
HC15-1	165	62	62	25.5	5	37	43	85	32	21	38	M20	—	1.5x60°	V-215, V-218, V-215R, V-218R	12.5
HC24-1	180	64	70	25	9	40	60	80	32	21	45	M20	—	3.0x60°	N-220, N-224, V-221, V-224, V-221R, V-224R	15.8
HC32-1	210	74	90	25	9	40	80	90	32	21	65	M20	—	3.0x60°	V-232	29.2
HC15-2	156	64	70	26	9	34	50	72	32	21	45	M20	—	3.0x60°	V-215(P3.0), V-218(P3.0)	13.4

Soft jaw for draw down power chuck

DIM Model	C-1	C-2	C-3	C-4	C-5	C-6	C-7	C-8	C-9	C-10	C-11	C-12	C-13	Matching Chuck	3 Jaw Weight (kg)	Reference
DR-06	70	35	34	10	6	43	—	10	23	15.5	21	M14	2.5	DR-06	1.5	Fig-1
DR-08	84	40	44.5	16	7	53	26	12	20	13.5	29	M12	3.5	DR-08	2.7	Fig-2

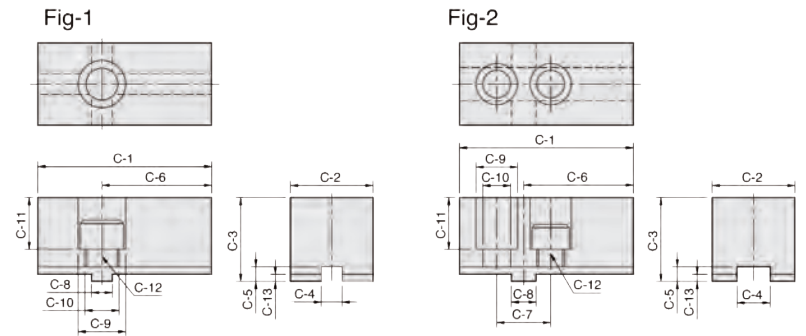

Soft jaw for ball swing lock chuck

DIM Model	C-1	C-2	C-3	C-4	C-5	C-6	C-7	C-9	C-10	C-11	C-12	Matching Chuck	3 Jaw Weight (kg)
BL-12	108	70	70	57.1	3.3	19	44.45	25	17	59	M16	BL-12	10.6

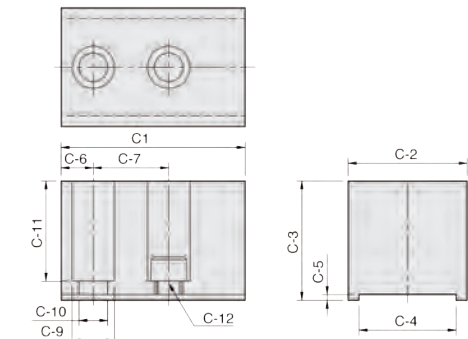

Soft jaws for pneumatic power chuck

DIM Model	C-1	C-2	C-3	C-4	C-5	C-6	C-7	C-8	C-9	C-10	C-11	C-12	C-13	Matching Chuck	3 Jaw Weight (kg)
PB600	205	60	60	25.5	6	25	38	104	32	21	44	M20	55	PB-ES600	13.5
PB850	320	80	80	30	7	35	60	165	38	26	53	M24	110.5	PB-ES850	40.2

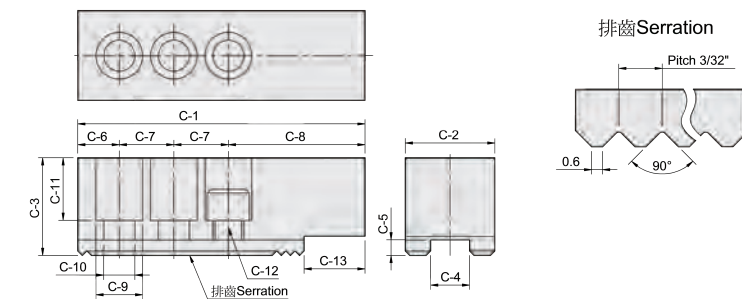

HJ

Hard jaw for hydraulic power chuck

1. Hard jaw for hydraulic power chucks.
2. Hard jaw for CNC lathe.



Fig-1

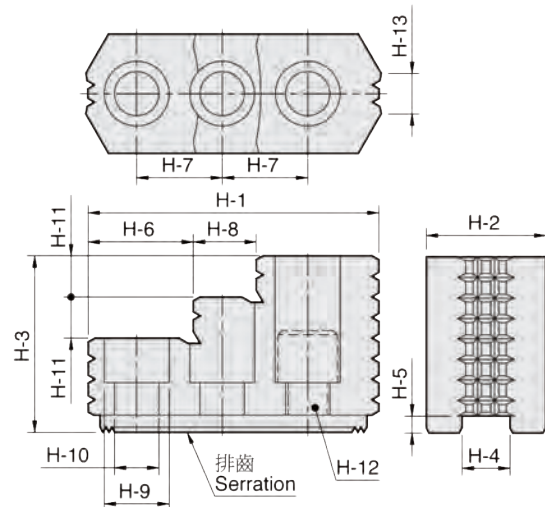
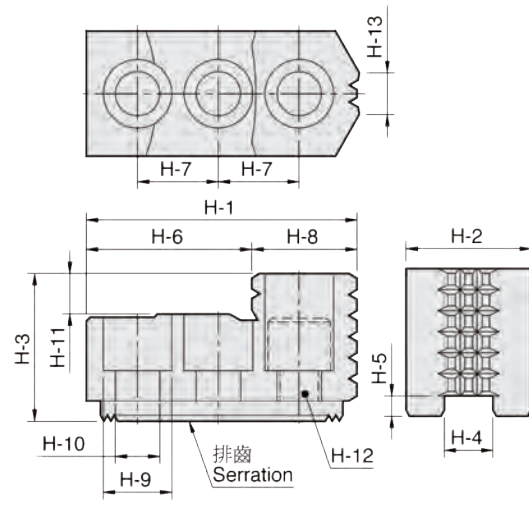

Fig-2



UNIT : mm

SPEC Model	H-1	H-2	H-3	H-4	H-5	H-6	H-7	H-8	H-9	H-10	H-11	H-12	H-13	Serration Pitch	Reference	Matching Chuck	3 Jaw Weight (kg)
HJ05	53	23	27.5	10	4	30.5	14	22.5	13.5	8.5	10	M8	6	1.5x60°	Fig-2	N-204, N-205	0.4
HJ06	67	31	35	12	5	39.5	20	27.5	17	11	12	M10	11	1.5x60°	Fig-2	N-206, V-206	1.0
HJ08	86	35	51	14	5	31	25	18	19	13	12	M12	12	1.5x60°	Fig-1	N-208, V-208	1.9
HJ10	99.5	40	54	16	5	43	30	17	19	13	13	M12	15	1.5x60°	Fig-1	N-210, V-210	2.9
HJ12	103	50	52	21	4	62.5	30	40.5	25	17	17	M16	30	1.5x60°	Fig-2	N-212	3.5
HJ12-1	103	50	52	18	5	62.5	30	40.5	22	15	17	M14	30	1.5x60°	Fig-2	V-212	3.6
HJ15	149	62	86	22	8	63	43	34	32	21	20	M20	40	1.5x60°	Fig-1	N-215, N-218	9.6
HJ15-1	149	62	86	25.5	5	63	43	34	32	21	20	M20	40	1.5x60°	Fig-1	V-215, V-218	9.5
HJ24-1	159.5	80	90	25	9	104.5	50	55	32	21	40	M20	55	3.0x60°	Fig-2	N-220, N-224, N-232, V-221, V-224, V-232	14.3
PB600	140	60	75	25.5	6	50.35	38	49.86	31	21	19	M20	21.1	3/32"x90°	Fig-1	PB-ES600	7.2
PB850	220	75	85	30	6.5	130	62	90	38	26	30	M25	35	3/32"x90°	Fig-2	PB-ES850	20.2



ADAPTER

Mounting adapter on short taper spindle noses DIN55026

TYPE1

UNIT : mm

DIM Model	Spindle Nose	C	F	H	K	E	Matching Chuck
N-205A4	A4	110	63.513	82.55	3-11	15	N-205
NT-205A4	A4	110	63.513	82.55	4-11	15	NT-205
N-206A5	A5	140	82.563	104.78	6-11	15	N-206, NB-306, V-206, DR-06
NT-206A5	A5	140	82.563	104.78	6-11	15	NT-206, VT-206
NIT-206A5	A5	140	82.563	104.78	4-11	15	NIT-206
N-208A6	A6	170	106.375	133.35	6-13	17	N-208, NB-208, V-208, DR-08
NT-208A6	A6	170	106.375	133.35	6-13	17	NT-208, VT-208
NIT-208A6	A6	170	106.375	133.35	4-13	17	NIT-208
NHT-208A6	A6	170	106.375	133.35	6-13	17	NHT-208
N-210A8	A8	220	139.719	171.45	6-17	18	N-210, N-212, NB-210, V-210, V-212, NB-310, V-212R, BL-12
NT-210A8	A8	220	139.719	171.45	6-17	18	NT-210, NT-212, VT-210, VT-212
NIT-210A8	A8	220	139.719	171.45	4-17	18	NIT-210, NIT-212, VIT-212
N-215A11	A11	300	196.869	235	6-21	22	N-215, N-218, NB-212, V-215, V-218, VIT-212R, V-215R, V-218R
NT-215A11	A11	300	196.869	235	6-21	22	NT-215, VT-215, NT-218
NIT-215A11	A11	300	196.869	235	4-21	22	NIT-215, VIT-218, NIT-218
V-224A15	A15	380	285.775	330.2	6-25	27	N-220, NB-215, NB-218, V-232RD, V-221R, V-224R, V-232R
VIT-224A15	A15	380	285.775	330.2	8-25	27	VIT-224R, VIT-232R
N-224A20	A20	520	412.775	463.6	6-25	25	N-224, N-232, V-240, V-250, NIT-224

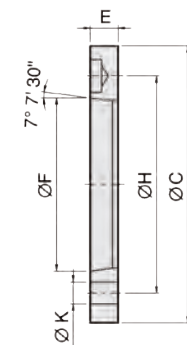

TYPE2

UNIT : mm

DIM Model	Spindle Nose	C	F	H	K	G	V	E	Matching Chuck
N-206A4	A4	140	63.513	82.55	11	104.78	M10	20	N-206, NT-206, NIT-206, V-206
N-208A5	A5	170	82.563	104.78	11	133.35	M12	23	N-208, NT-208, NIT-208, NHT-208, NB-208, V-208, VT-208
N-210A6	A6	220	106.375	133.35	13	171.45	M16	25	N-210, NT-210, NIT-210, N-212, NT-212, NIT-212, V-210, VT-210, V-212, VT-212, VIT-212, NB-210, NB-310
N-215A8	A8	300	139.719	171.45	17	235	M20	33	N-215, NT-215, NIT-215, N-218, NB-212, V-215, VT-215, V-218, VIT-218, NIT-218
N-220A11	A11	380	196.869	235	21	330.2	M24	41	N-220, VIT-232, NB-215, NB-218, VIT-224
N-224A11	A11	520	196.869	235	21	463.6	M24	45	N-224, N-232, V-240, V-250, NIT-224
N-224A15	A15	520	285.775	330.2	25	463.6	M24	42	N-224, N-232, V-240, V-250, VIT-240, VIT-250, NIT-224, VE-250
V-224A8	A8	380	139.719	171.45	17	330.2	M24	33	V-224, V-224, N-220, NB-215
V-224A11	A11	380	196.869	235	21	330.2	M24	27	V-224, V-224, V-232
VE-263A20	A20	720	412.775	463.6	27	647.6	M30	50	VE-263, VE-279

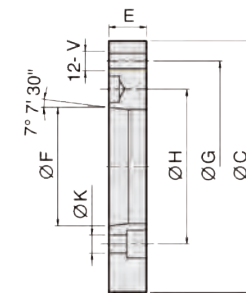

TYPE3

UNIT : mm

DIM Model	Spindle Nose	C	F	H	K	G	V	W	E	Matching Chuck
N-205A5	A5	110	82.563	104.78	11	82.55	M10	128	32	N-205, NT-205
N-206A6	A6	140	106.375	133.35	13	104.78	M10	165	35	N-206, NT-206, NB-306, V-206, VT-206, NIT-206
N-208A8	A8	170	139.719	171.45	17	133.35	M12	208	40	N-208, NT-208, NIT-208, NB-208, V-208, VT-208, NHT-208
N-212A11	A11	220	196.869	235	21	171.45	M16	278	50	N-210, NT-210, NIT-210, N-212, NT-212, NIT-212, NB-210, V-210, V-212, VT-210, VT-212, VIT-212, VIT-212
N-215A15	A15	300	285.775	330.2	25	235	M20	378	57	N-215, NT-215, NIT-215, N-218, NB-212, V-215, VT-215, V-218, VIT-218, NIT-218
N-224A20	A20	380	412.775	463.6	26	330.2	M24	520	58	N-220, V-221R, V-224R, V-232R

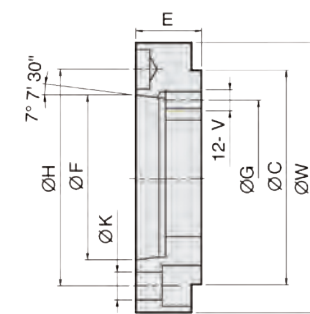

T-NUTS

Suitable for power chuck



F52

High speed and light weight type strong finger chuck for aluminum wheel

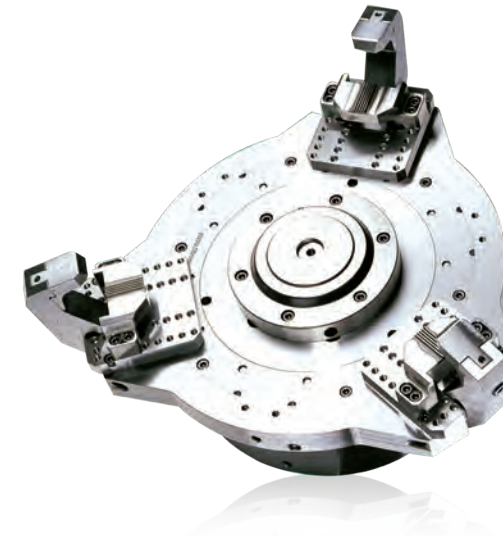

1. All sliding surfaces are hardened and ground for accurate actual running and long service repeatability.
2. Mounting : Adaptor mounting to fit with DIN, ISO, BS, ASA, B5-9 type A spindles.

Fig. 1

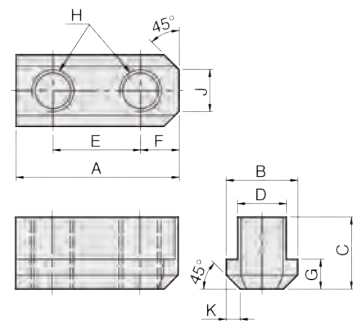

Fig. 2

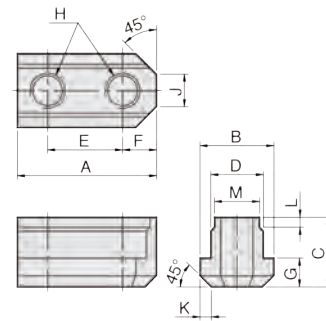
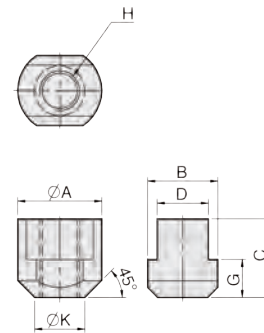
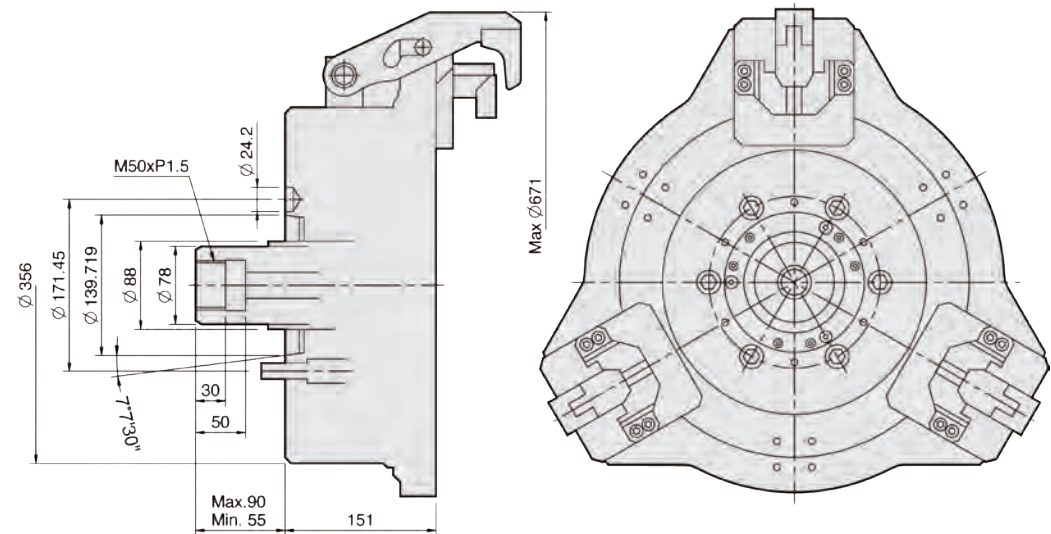

Fig. 3



UNIT : mm

DIM Model	A	B	C	D	E	F	G	H	J	K	L	M	Fig	Matching Chuck
N-205	26	14.5	15	10	14	6	5.5	M8	5	2	—	—	1	N-204, N-205
N-206	36	17.5	18.5	12	20	8.2	7.5	M10	8	2.5	—	—	1	N-206, NB-306
N-208	46.5	20.5	20.5	14	25	10.5	8.5	M12	12	4	—	—	1	N-208, NB-208
N-210	51	22.5	21.5	16	30	11	8.5	M12	11	3	—	—	1	N-210, NB-210
N-212	55.5	29.5	27.8	21	30	12	11.5	M16	13	4.5	—	—	1	N-212, NB212
N-215	80	33.5	45.5	24	43	17	16.5	M20	11	5	8	22	2	N-215, N-218
V-206	36.5	17.5	22.5	12	20	7.5	7.5	M10	6	3	—	—	1	V-206, NHT-208
V-208	48	20.5	25.5	14	25	11	9.5	M12	8	4	—	—	1	V-208
V-210	55	22.5	25.5	16	30	11	9.5	M12	8	4	—	—	1	V-210
V-212	55.5	26.5	33.5	18	30	11.5	13.5	M14	11	5	—	—	1	V-212
V-215	42	35	39.2	25.5	—	—	19	M20	—	25	—	—	3	V-215, V-218
V-215 26 M20	42	35	41.2	26	—	—	19	M20	—	25	—	—	3	V-215P3.0
V-224	46	37.5	45	25	—	—	19	M20	—	26.5	—	—	3	N-220, N-224, V-221, V-224, V-232



UNIT : mm

SPEC Model	Matching Wheel Size	Out. Dai. Of Chuck (mm)	Matching Spindle	Max. Pull Force kN(kgf)	Max. Gripping Force kN(kgf)	Max. Operating Pressure MPa(kgf / cm ²)	Max. Speed (r.p.m.)	Weight (Without Jigs) (kg)	Matching Cylinder
F52A8	12"-18"	521	A2-8	33.9(3456)	32.4(3303)	3.3(33.6)	2800(18"2200)	98	MS125C35

F61

High speed and light weight type strong finger chuck for aluminum wheel

1. All sliding surfaces are hardened and ground for accurate actual running and long service repeatability.
2. Mounting : Adaptor mounting to fit with DIN, ISO, BS, ASA, B5-9 type A spindles.



F66

High speed and light weight type strong finger chuck for aluminum wheel

1. All sliding surfaces are hardened and ground for accurate actual running and long service repeatability.
2. Mounting : Adaptor mounting to fit with DIN, ISO, BS, ASA, B5-9 type A spindles.

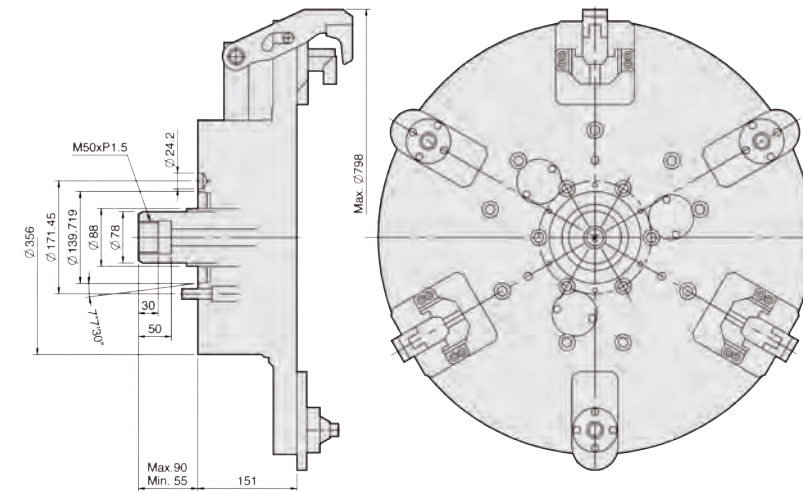
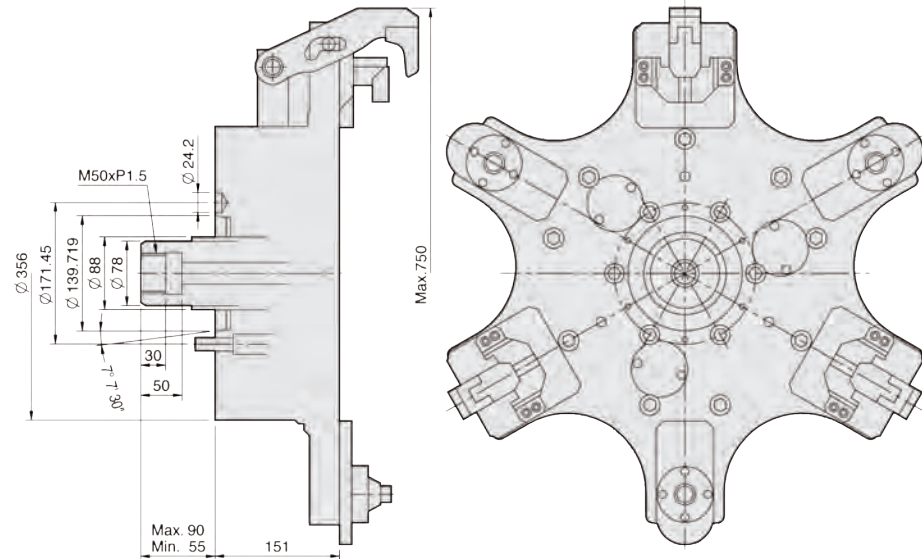

SPEC Model	Matching Wheel Size	Out Dai. Of Chuck (mm)	Matching Spindle	Max. Pull Force kN(kg)	Max. Gripping Force kN(kg)	Max. Operating Pressure MPa(kg / cm ²)	Max. Speed (r.p.m.)	Weight (Without Jigs) (kg)	Matching Cylinder
F61A8	13"-22"	610	A2-8	33.9(3456)	32.4(3303)	3.3(33.6)	1500	145	MS125C35

UNIT : mm

SPEC Model	Matching Wheel Size	Out Dai. Of Chuck (mm)	Matching Spindle	Max. Pull Force kN(kg)	Max. Gripping Force kN(kg)	Max. Operating Pressure MPa(kg / cm ²)	Max. Speed (r.p.m.)	Weight (Without Jigs) (kg)	Matching Cylinder
F66A8	19"-24"	660	A2-8	33.9(3456)	32.4(3303)	3.3(33.6)	1500	182	MS125C35

UNIT : mm

BL

3-jaw ball swing lock chuck



1. The chuck can attract the workpiece and hold it on.
The jaw operates in two stages :
Clamping pull back, so it can hold the workpiece exactly on the position in front of the chuck, and make it under the stabile situation.
2. The chuck can grasp the workpiece on both O.D. and I.D. clamping.
The chuck can switch between O.D. and I.D. clamping mode by a simple operation.
3. The chuck can grasp the part of the taper. The chuck can exactly grasp the black surface of the cast irons, which has draft.
So the discard process can be ignored on the chucking part of the workpiece. (It can grasp up to a 20 degree taper when using a clipper.)
4. The jaw can equalize on the O.D. clamping, so it can grasp the workpiece steady. (Jaw self-equalizing to max 5°)
5. Dustproof performance is excellent. It is differ from regular general purpose chuck. It is structurally dustproof. Especially there is a dustproof seal in the part of lock arm to prevent the dust.

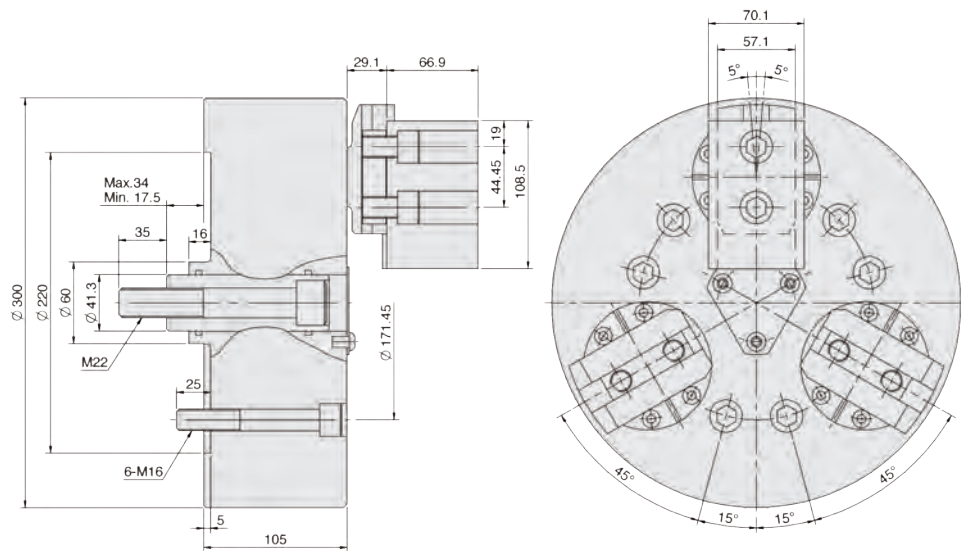

DR

3-jaw draw down power chuck



Draw down power chuck feature of radial clamping will lead to almost no work piece uplifting displacement; for machining casting and forging part:

1. For the clamped work-piece is appressed to the surtace, chucks are suitable for heavy machining.
2. Chuck Actutors with cylindrical structure are durable and ensures high clamping repeatability.
3. Accurate self-centering and pull back features are adequate or precise length control machining requirements.

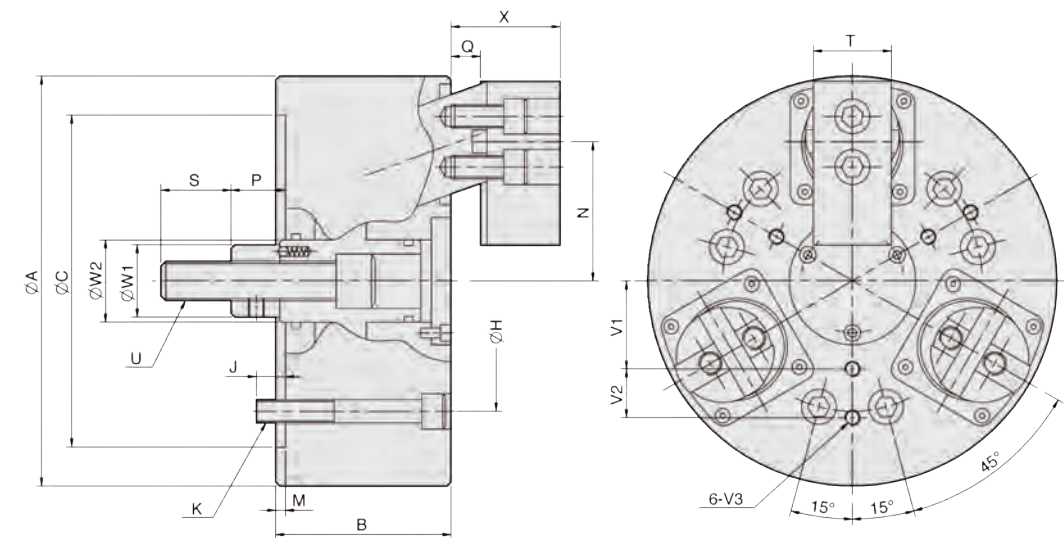

SPEC Model	Plunger Stroke (mm)	Jaw Stroke (In Dia.) (mm)	Max. Full Force kN(kgf)	Max. Gripping Force kN(kgf)	Max. Operating Pressure MPa(kgf / cm²)	Max. Speed (r.p.m.)	Weight (kg)	Moment Of Inertia I (kg · m²)	Matching Cylinder	Matching Soft Jaw	Gripping Range O.D. Range / I.D. Range
BL-12	17.5	12.4	40.7(4152)	122(12440)	2.8(28.5)	2800	65	0.18	MS150C	BL-12	Ø63-Ø240 / Ø127-Ø305

UNIT : mm

SPEC Model	Plunger Stroke (mm)	Jaw Stroke (In Dia.) (mm)	Max. Pull Force kN(kgf)	Max. Gripping Force kN(kgf)	Max. Operating Pressure MPa(kgf / cm²)	Max. Speed (r.p.m.)	Weight (kg)	Moment Of Inertia I (kg · m²)	Matching Cylinder	Matching Soft Jaw	Gripping O.D. Range (mm)
DR-06	10	7.2	15(1530)	25(2549)	2.1(21.4)	3500	15	0.05	MS105C	DR06-HC	Ø35-Ø165
DR-08	10	7.2	25(2590)	45(4589)	2.5(25.5)	3000	25	0.14	MS125C	DR08-HC	Ø40-Ø210

DIM Model	A	B	C	H	J	K	M	N max.	N min.	P max.	P min.	Q max.	Q min.	S	T	U	W1	W2	X max.	X min.	V1	V2	V3
DR-06	165	85	140	104.78	16	6xM10	5	58	54.4	33	23	14	4	36	35	M16x2.0	32	33.5	45	35	35	20	M6x12
DR-08	210	90	170	133.35	15	6xM12	5	71.3	67.7	38	28	15	5	36	40	M20x2.5	37	42	56	46	45	25	M8x16



P165

Floating plate center chuck

- Suitable for easy one step cutting of thin holes, plate and outside diameter.



HN

3-jaw extra high speed through-hole power chuck(adapter included)

1. Possible 10,000 r.p.m. highest speed chuck.
2. Model HN chucks are assembled with adaptor for ASA B5.9 type A spindles.
3. Model HN chucks are manufactured from high grade alloy steel. All sliding surfaces are hardened and ground for accurate actual running and long service repeatability.

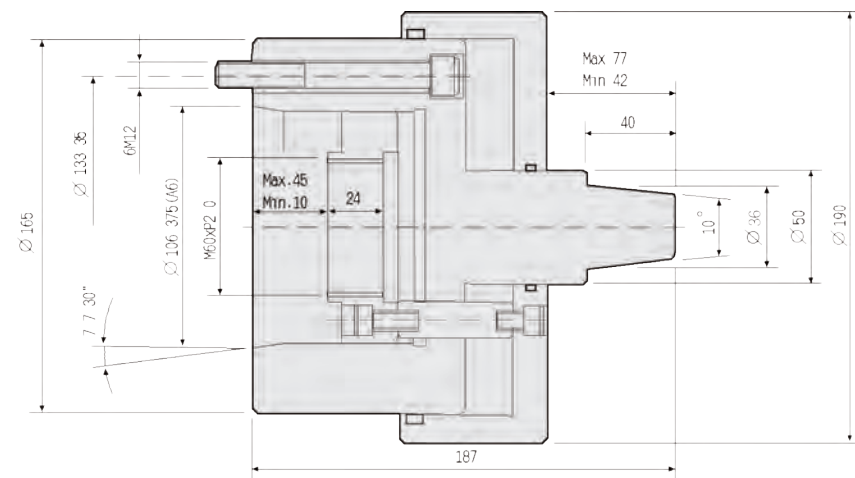

Possible processing range

GRIPPING CHARACTERISTIC GRAPH

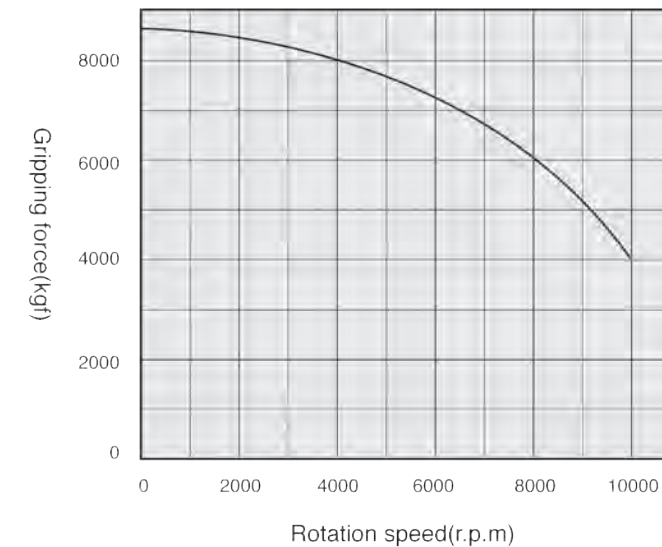

UNIT : mm

SPEC Model	Plunger Stroke (mm)	Max. Operating Pressure MPa(kgf / cm ²)	Max. Speed (r.p.m.)	Weight (kg)	Moment Of Inertia I (kg · m ²)	Matching Cylinder
P165	35	1.0(10)	6000	18.5	0.02	MS125C35

UNIT : mm

SPEC Model	Through-Hole (mm)	Plunger Stroke (mm)	Jaw Stroke (In Dia.) (mm)	Max. Pull Force kN(kgf)	Max. Gripping Force kN(kgf)	Max. Operating Pressure MPa(kgf / cm ²)	Max. Speed (r.p.m.)	Weight (kg)	Moment Of Inertia I (kg · m ²)	Matching Cylinder	Matching Soft Jaw	Gripping O.D. Range (mm)
HN-06	Ø36	12	5.5	30(3050)	79.4(8100)	2.9(30)	10000	11.5	0.035	HG-1336	Model-A	Ø14-Ø51

PB-ES

Pneumatic power chuck



1. Air chuck for external clamping with built-in pneumatic cylinder.
2. Fast and clamping jaw stroke.
3. Clamping pressure control.
4. Clamping stroke control.

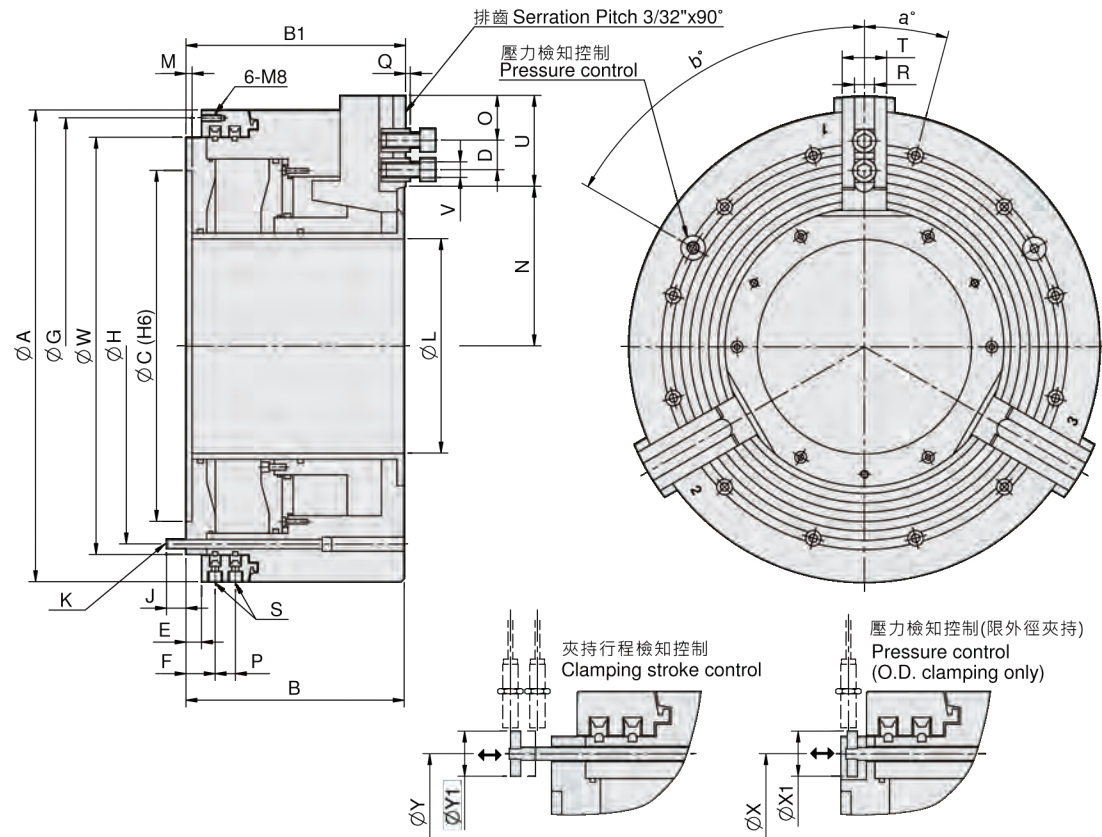

HC40-1

Soft jaw for hydraulic power chuck

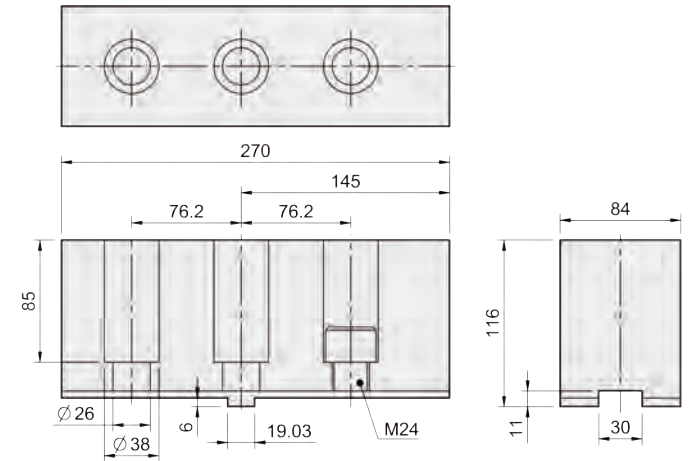

HJ40-1

Hard jaw for hydraulic power chuck

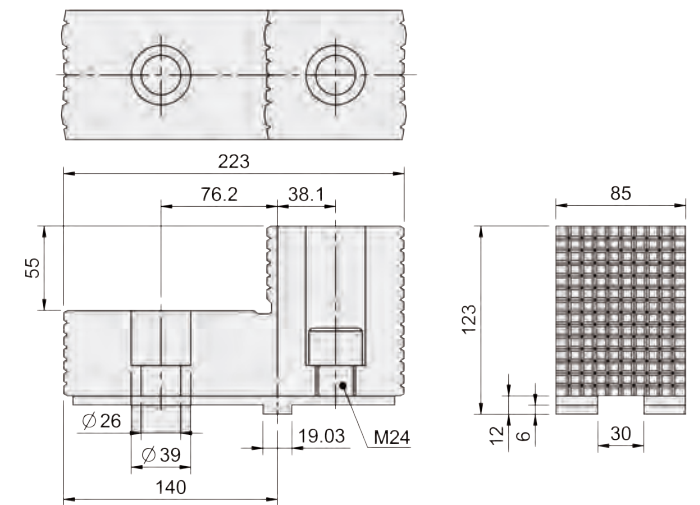

UNIT : mm

SPEC Model	Through-Hole (mm)	Total Stroke / Jaw (mm)	Fast Stroke / Jaw (mm)	Clamping Stroke / Jaw (mm)	Piston Area (cm ²)	Operating Pressure Min.-Max. (bar)	Gripping* Force (kN)	Max. Speed (r.p.m.)	Weight (kg)	Moment Of Inertia I (kg · m ²)	Air* Consumption (L)
600-275	275	25.4	16.9	8.5	954	2-10	180	1100	360	20.6	39.5
850-375	375	25.4	13.4	12	1342	2-10	250	750	980	110	68

*When operating pressure at 6 bar.

DIM Model	A	B	B1	C	D max./min.	E	F	G	H	J	K	L	M	N max./min.	O min.	P	Q	R	S	T	U	V	W	X	X1	Y	Y1	a°	b°
600-275	605	280	282	450	79/38	20	37	585	508	25	12-M12	275	8	204.6/179.2	14	26	3	25.5	G1/2	57	116.5	M20	535	508	35	508	35	15	60
850-375	850	352	354	700	140/47	25	44.5	830	745	30	12-M16	375	8	268/242.6	16	33	4	30	G1/2	75	182	M24	775	745	35	745	35	15	60

